

DE
ENG

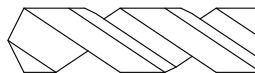

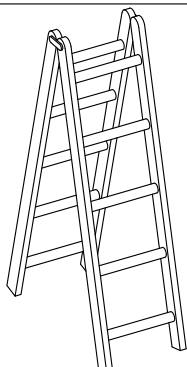

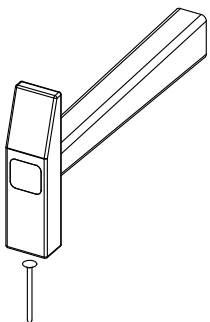

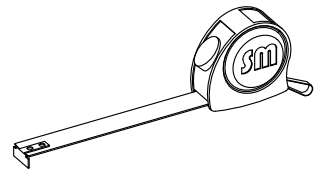
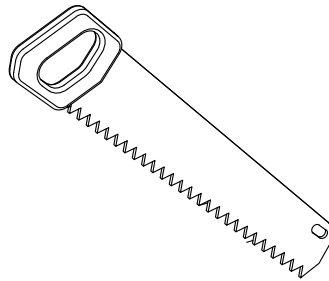
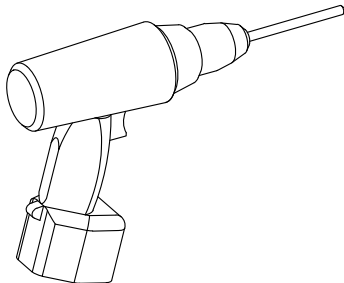
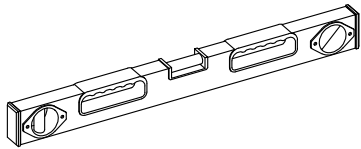
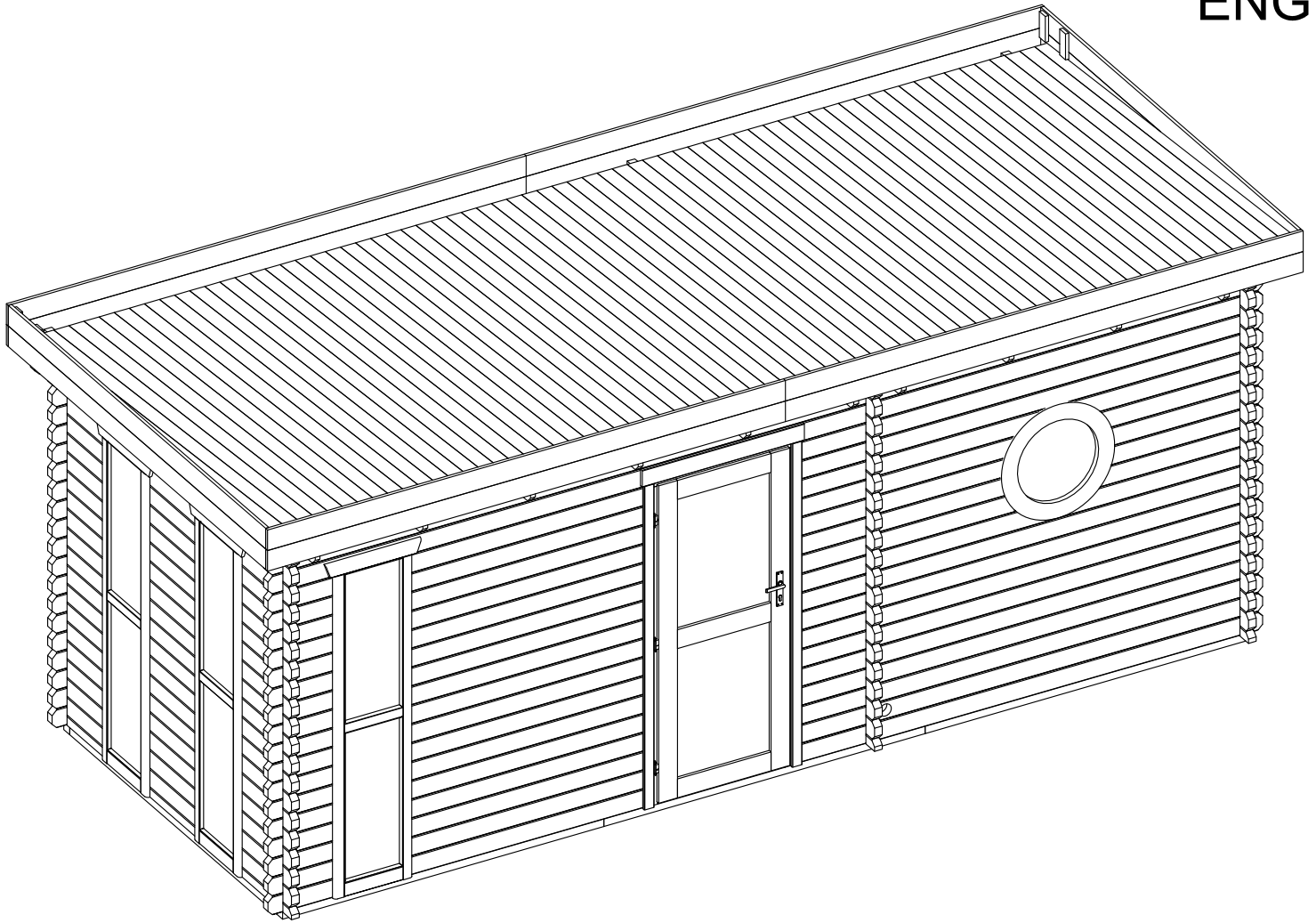
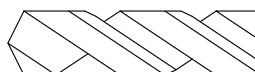

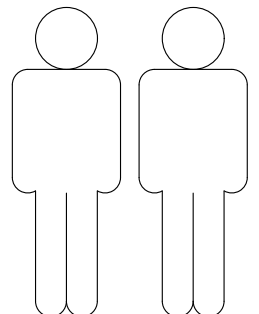

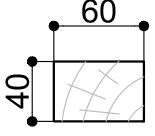



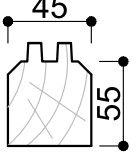
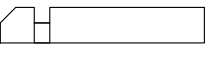
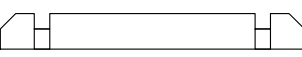
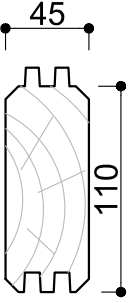
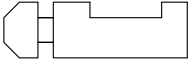

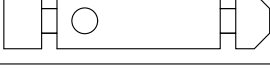
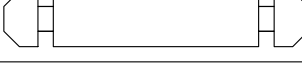
Ø4

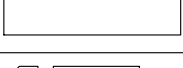

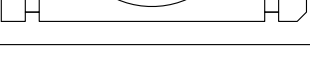
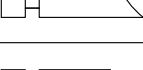
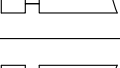

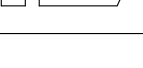
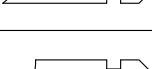

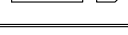



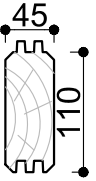
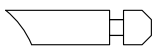

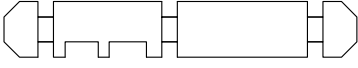
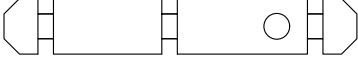

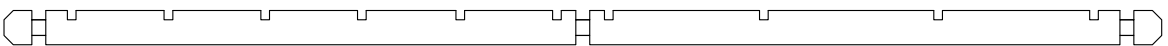
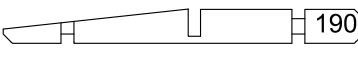

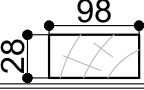
Ø10

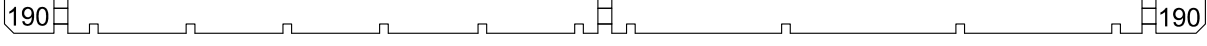
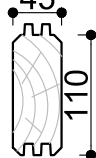
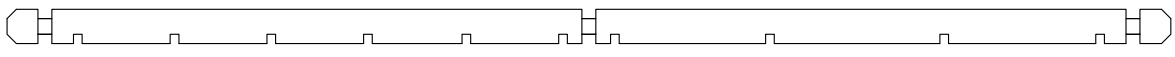

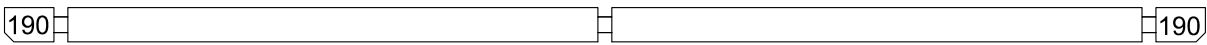
Dim.	Skizze/Sketch	Pos.	Länge/length (mm)	Stck. /Total	Name	Ref.
		①	2090	12	Fundamentbalken Foundation beam	283062
		②	1873	6		283121
		③	400	4		283084
		④	772	2	Mitte Brett Middle board	450001
		⑤	2400	2	Seiten Brett Side board	450004
		⑥	2222	1	Front Brett Front board	450053
		⑦	2721	10	Front Brett Front board	450028
		⑧	5800	19+1	Front, Zurück Brett Front, back board	450054
		⑨	2721	1	Front Brett Front board	450029
		⑩	2400	25+1	Seiten Brett Side board	450003
		⑪	772	34	Mitte Brett Middle board	450002
		⑫	533	34	Seiten Brett Side board	450021
		⑬	533	17	Seiten Brett Side board	450022
		⑭	411	16	Front Brett Front board	450036
		⑮	1411	16	Front Brett Front board	450055
		⑯	2721	1	Front Brett Front board	450030
		⑰	1391	1	Front Brett Front board	450031
		⑱	1241	1	Front Brett Front board	450032
		⑲	1241	1	Front Brett Front board	450033
		⑳	1391	1	Front Brett Front board	450034
		㉑	1070	1	Front Brett Front board	450006
	㉒	920	1	Front Brett Front board	450007	
	㉓	920	1	Front Brett Front board	450008	

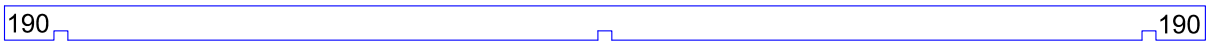
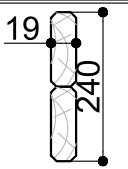
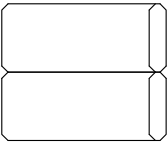
Alle maßen ca +/-3% / les dimensions des pièces peuvent évoluer +/- 3% / size tolerance +/- 3%

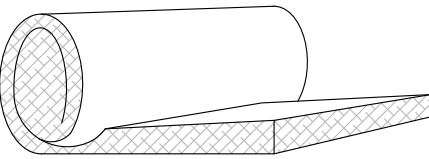
Dim.	Skizze/Sketch	Pos.	Länge/length (mm)	Stck. /Total	Name	Ref.	
		24	1070	1	Front Brett Front board	450009	
		25	2721	1	Front Brett Front board	450035	
		26	5800	1	Front Brett Front board	450056	
		27	5800	1	Zurück Brett Back board	450057	
		28	2400	1	Mitte Brett Middle board	450012	
			29	5800	2	Front, Zurück Brett Front, back board	450058
		30	2600	3	Seiten Brett Side board	452005	
		31	1300	3	Seiten Brett Side board	452006	
		32	2400	10	Sparren	454004	
		33	6000	1	Zurück Brett Back board	451013	
		34	5800	1	Front Brett Front board	450059	
		35	6000	1	Front Brett Front board	451014	
		36	6000	1	Sparren Rafter	454014	
		39	3020	4	Wind Brett Wind board	285088	
		40	2600	2	Wind Brett Wind board	285033	
	38				Mineralwolle Mineral wool		

		37a	2120	25 / 20	Dachholzer Roof board	284514
		37b	3360	25 / 20	Dachholzer Roof board	284531
		41	2540	69 / 55	Dachholzer Roof board	284513
		42	2120	20	Bodenholzer Floor board	283516
		43	3360	20	Bodenholzer Floor board	283549
		44	2135	12	Fussbodenleisten Baseboard	283241
		45	3360	4	Fussbodenleisten Baseboard	283297
		46	190	5	Zurück Brett Back board	404061
		47	250	5	Leiste Latte	287132
		48	2135	1	Wind Brett Wind board	286088
		49	2135	1	Wind Brett Wind board	286087
		50	1675	2	Wind Brett Wind board	286092
		51	1675	2	Wind Brett Wind board	286091
		52	200	2+1	Wind Brett Wind board	4023038
		F1	550x 550	1	Fenster Window	459101

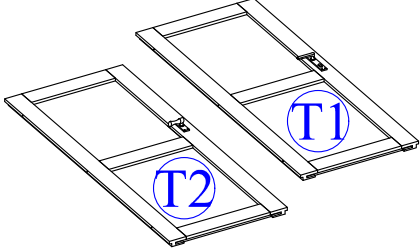
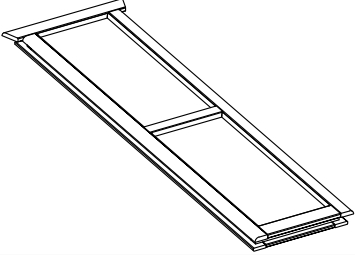
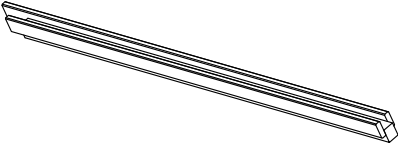
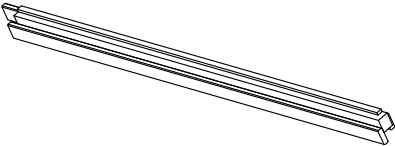
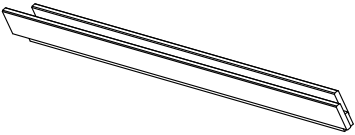
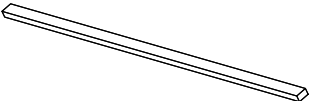
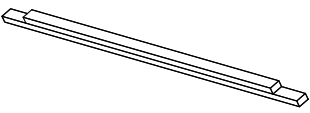
	T1	1850x 765	1	Tür Doors	289016
	T2	1850x 765	1		289017
	F	1870x 400	3	Fenster Window	459104
	TR1a	1973	1	Türrahmen links Door frame left	459201
	TR1b		1		459205
	TR2	1973	2	Türrahmen rechts Door frame right	459202
	TR3	945	2	Über Türrahmen Door frame top	459203
	TR4	745	1	Türstufe Door frame bottom	459204
	TR5	845	1	Türstufe Door frame bottom	459206

Alle maßen ca +/- 3% / les dimensions des pièces peuvent évoluer +/- 3%

1

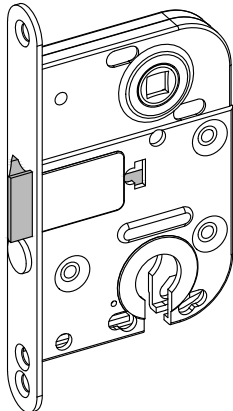

2

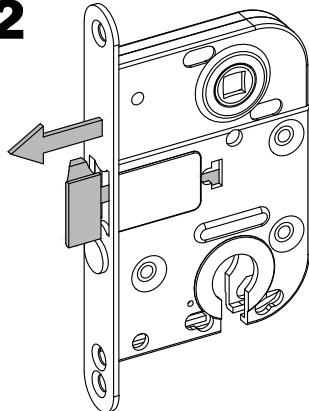

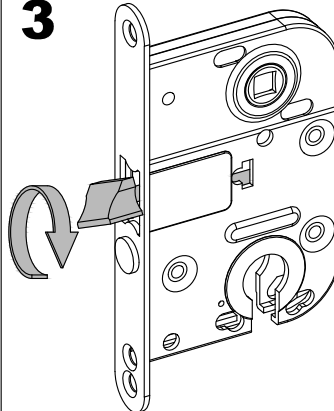

3

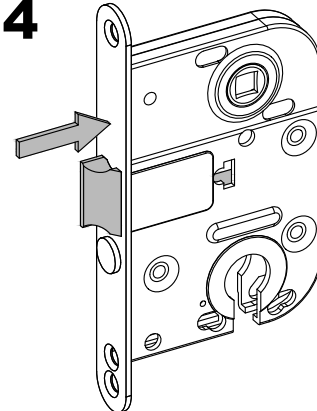

4

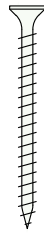

	Dim	Stck.
	Ø5.0 x 100	48
	Ø4.5 x 80	11
	Ø3.5 x 40	150
	Ø2.0 x 40	470
	Ø2.0 x 50	240

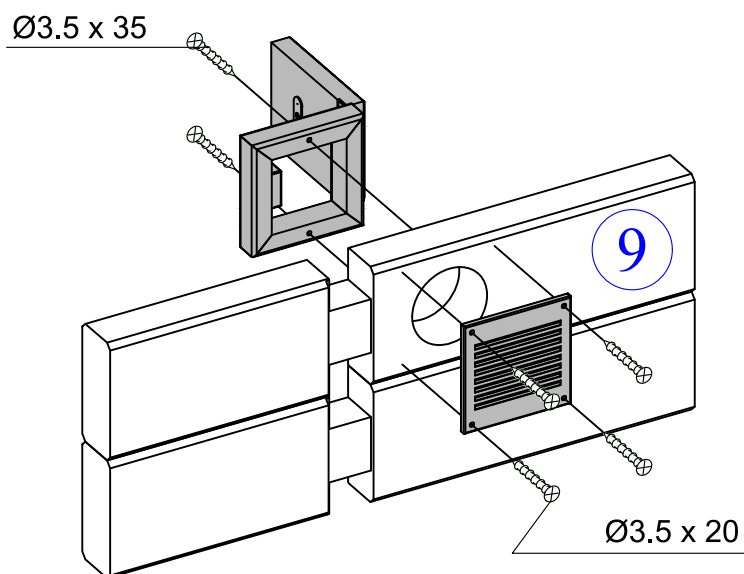
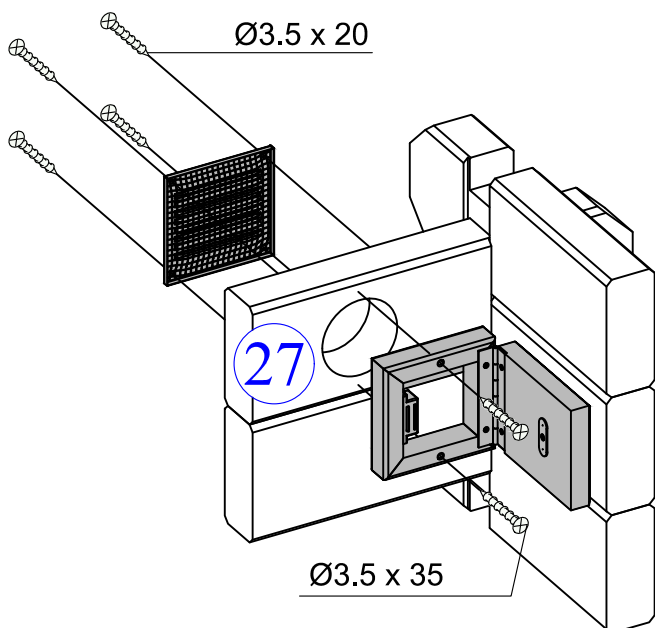
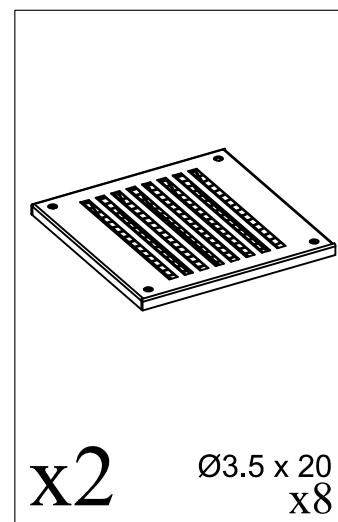
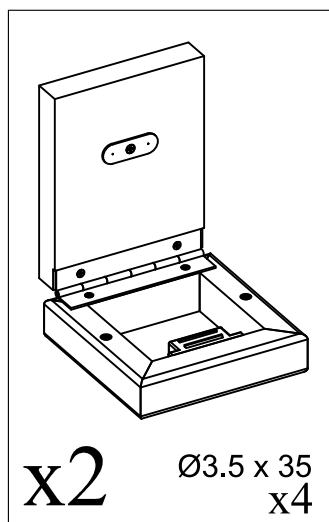
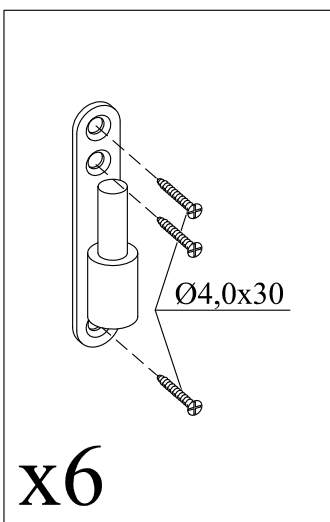
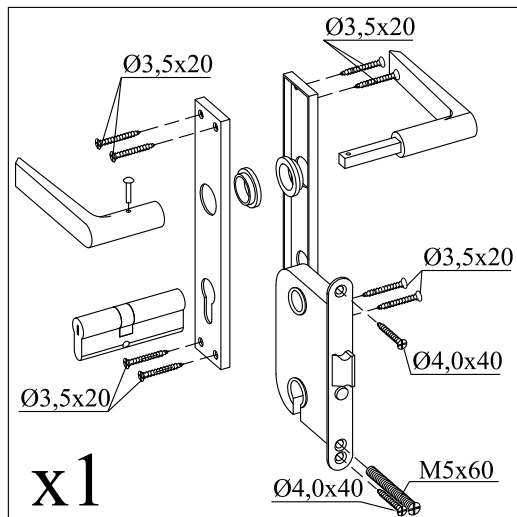
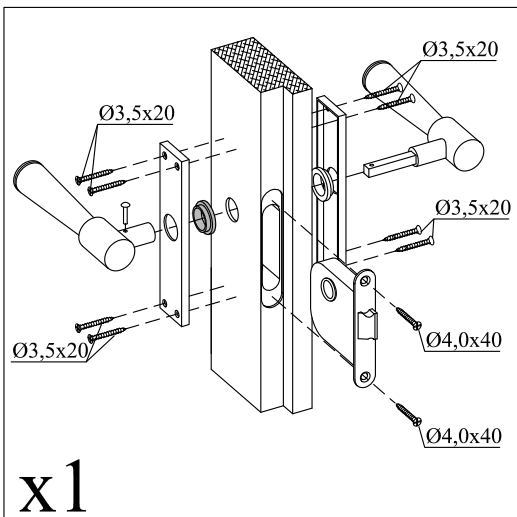

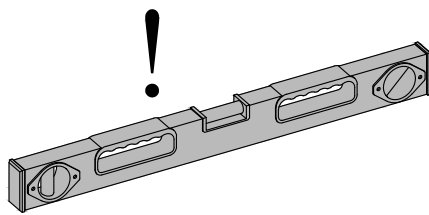
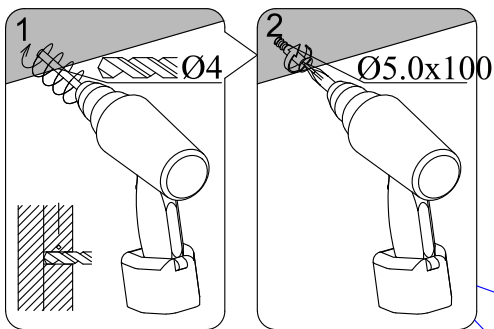

1

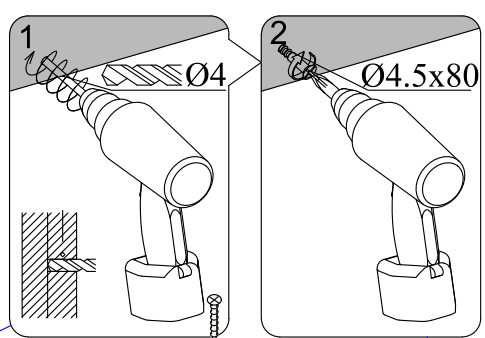
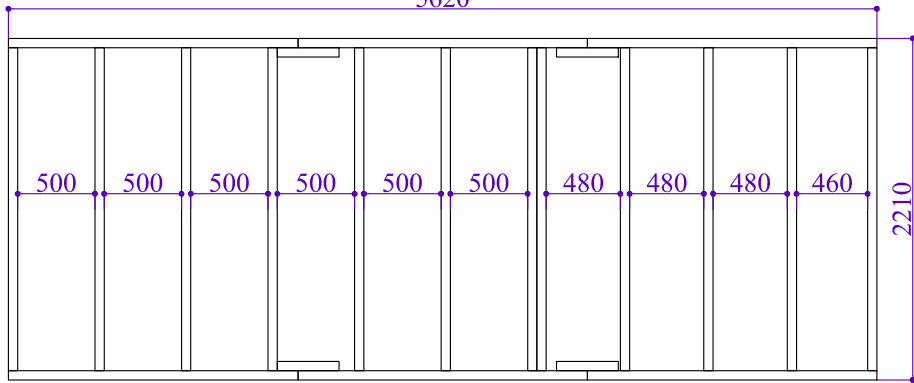
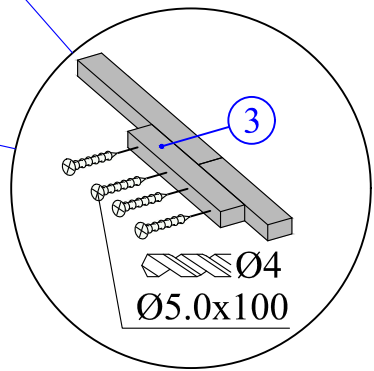
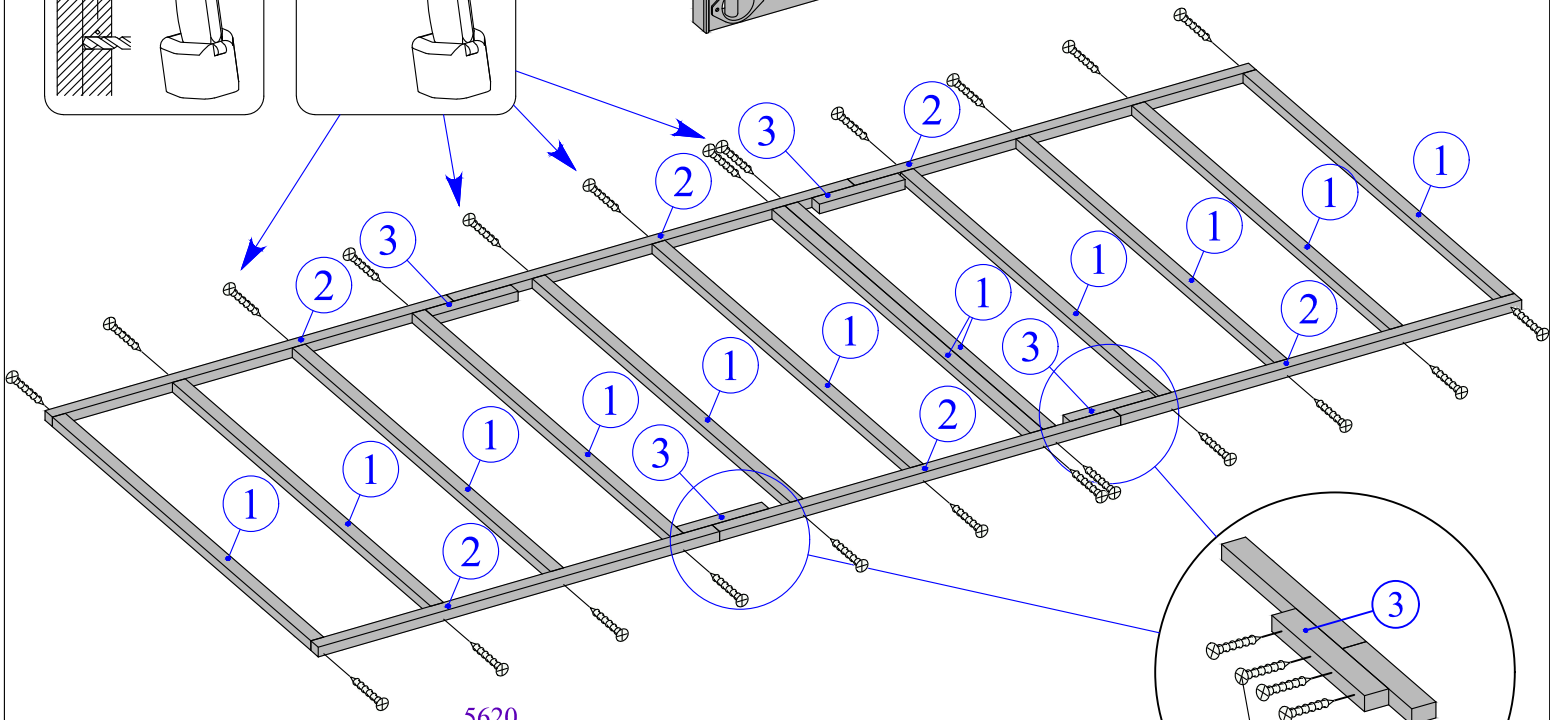

2

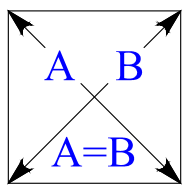

A=B=6039mm

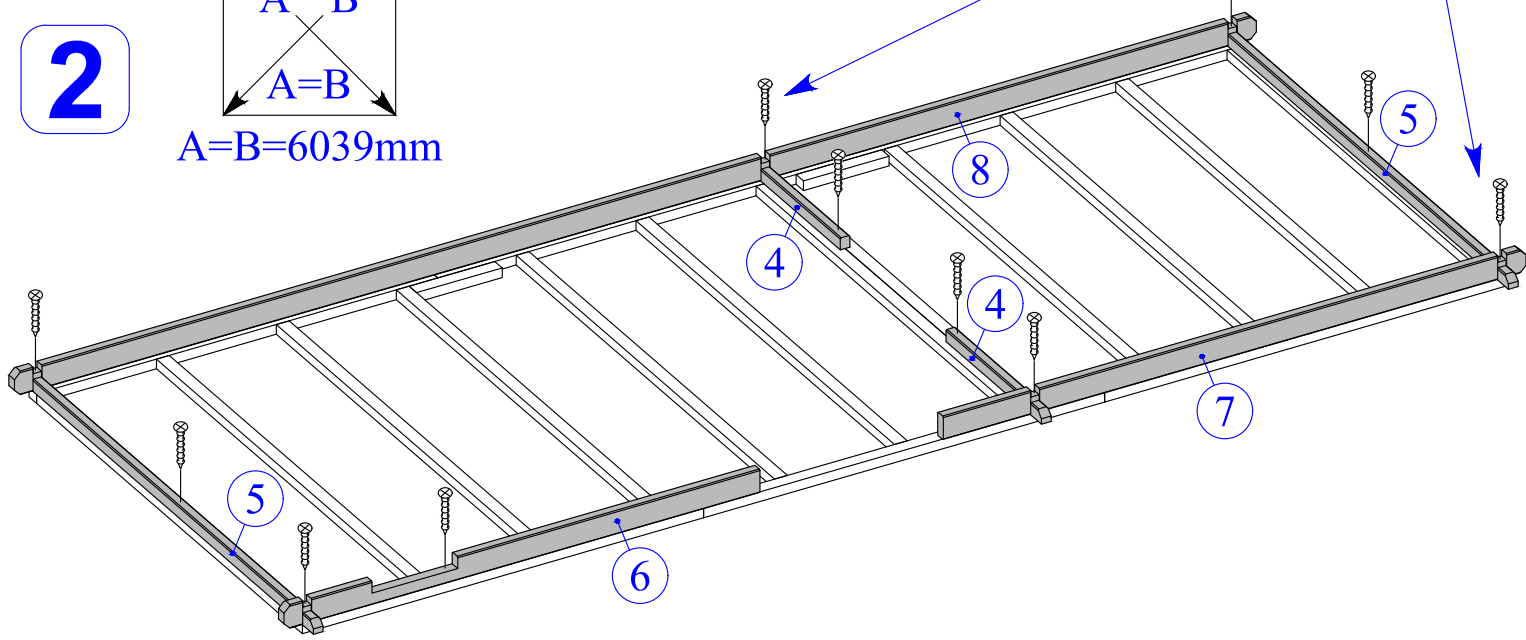

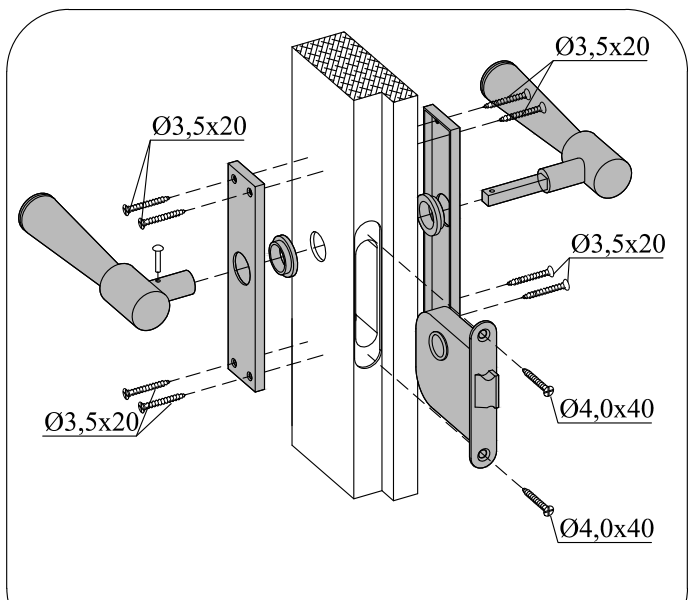
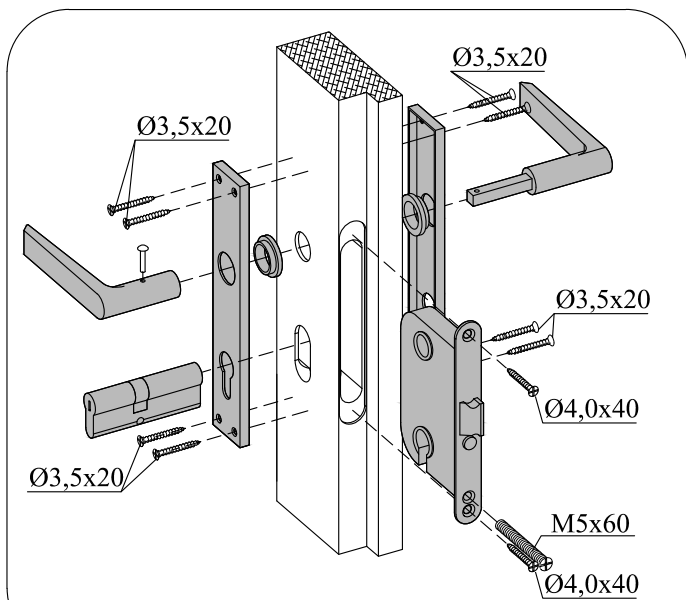
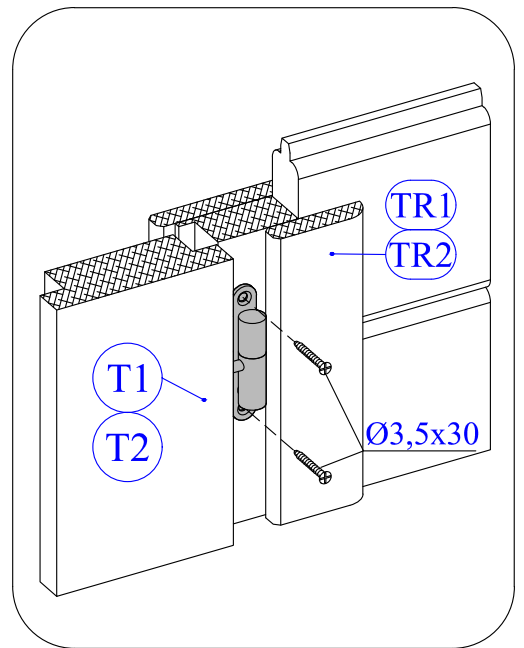
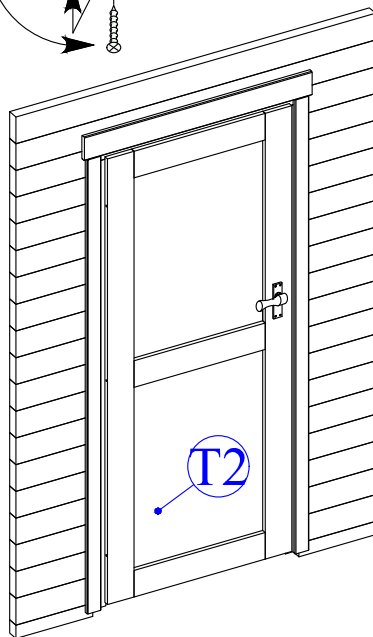
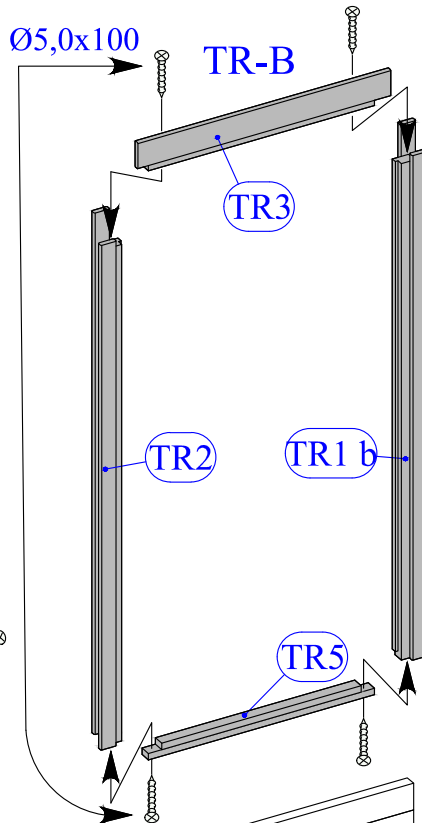
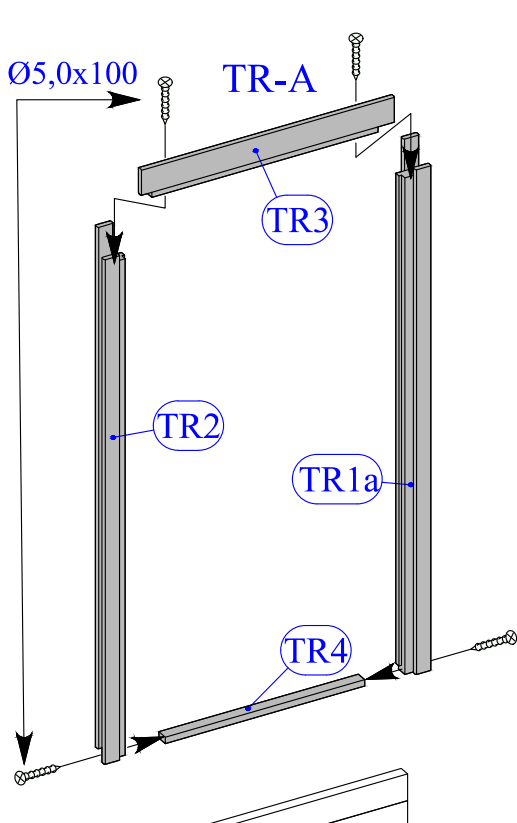

3

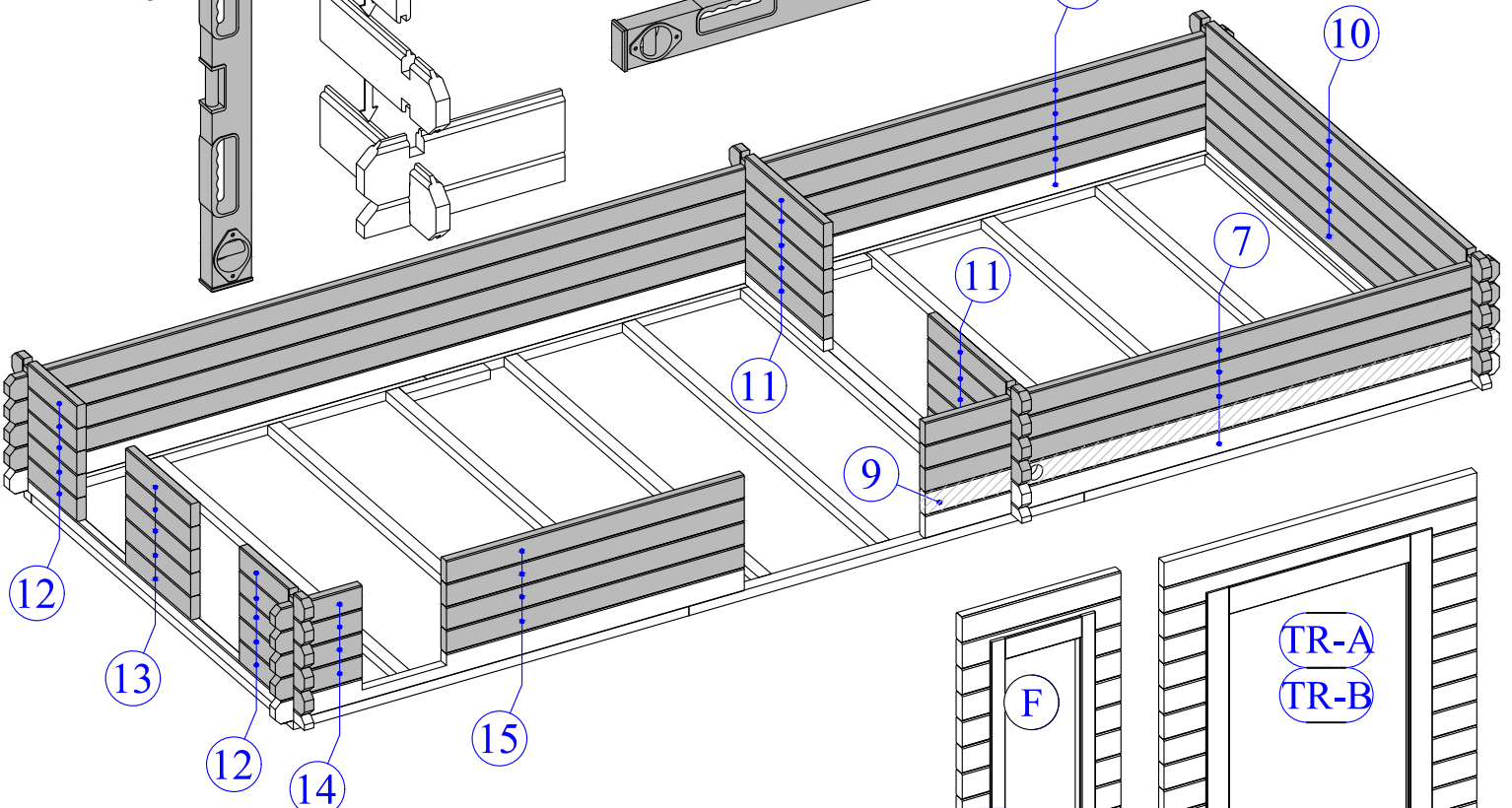
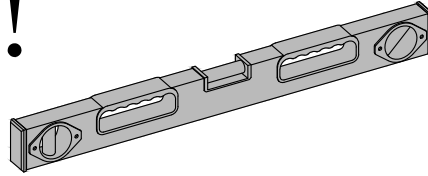
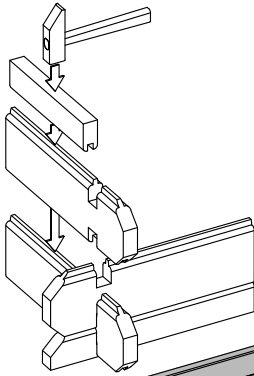
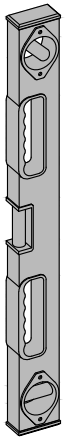

4

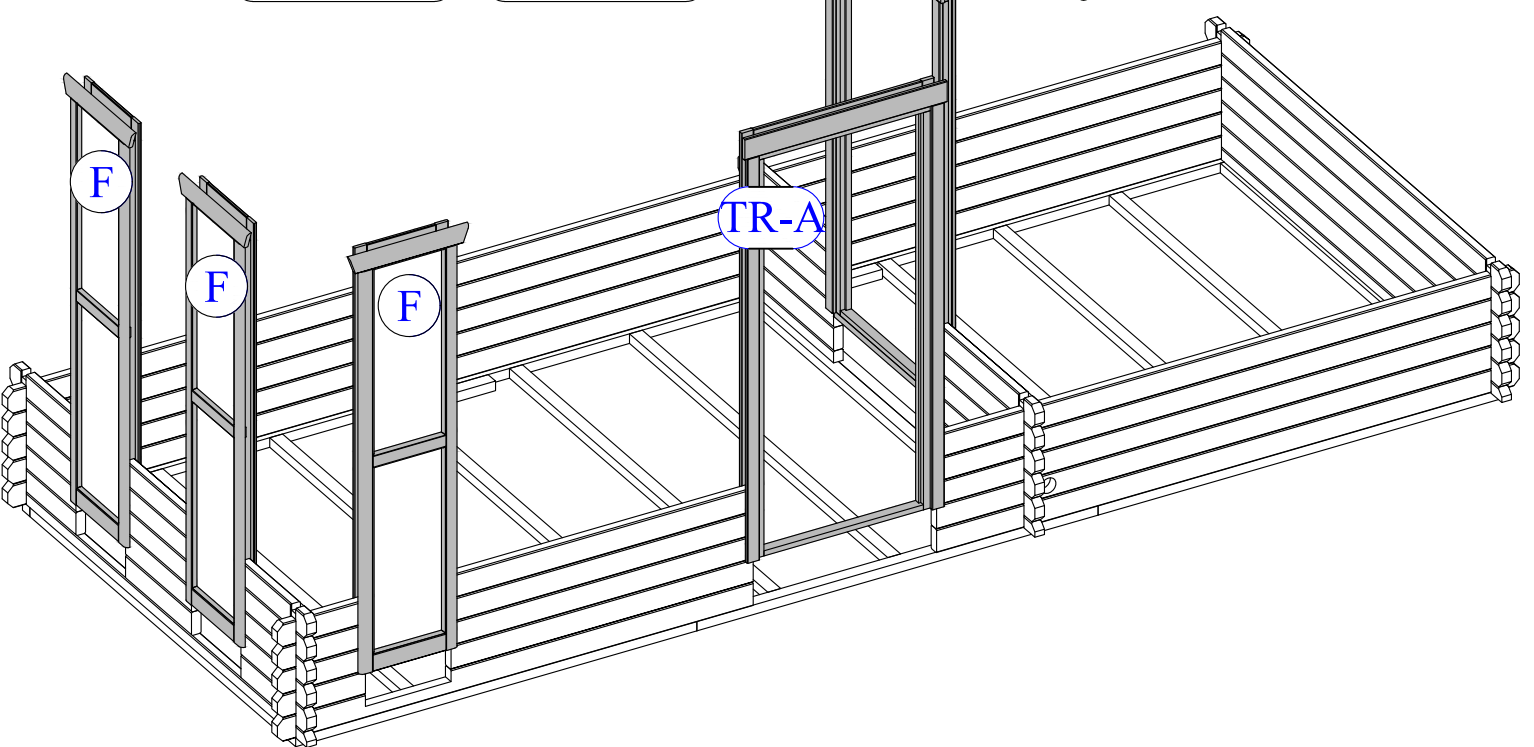
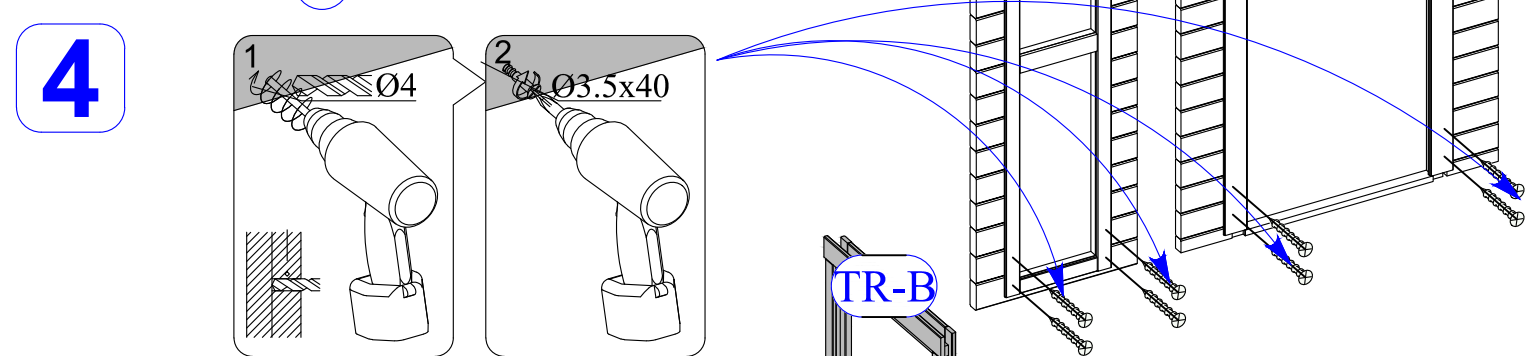
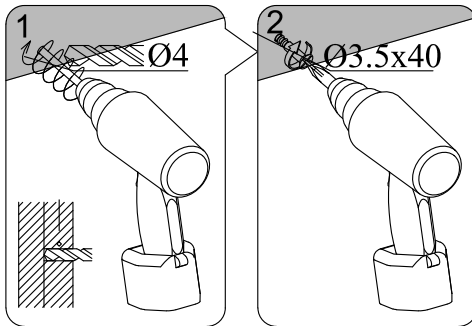

5

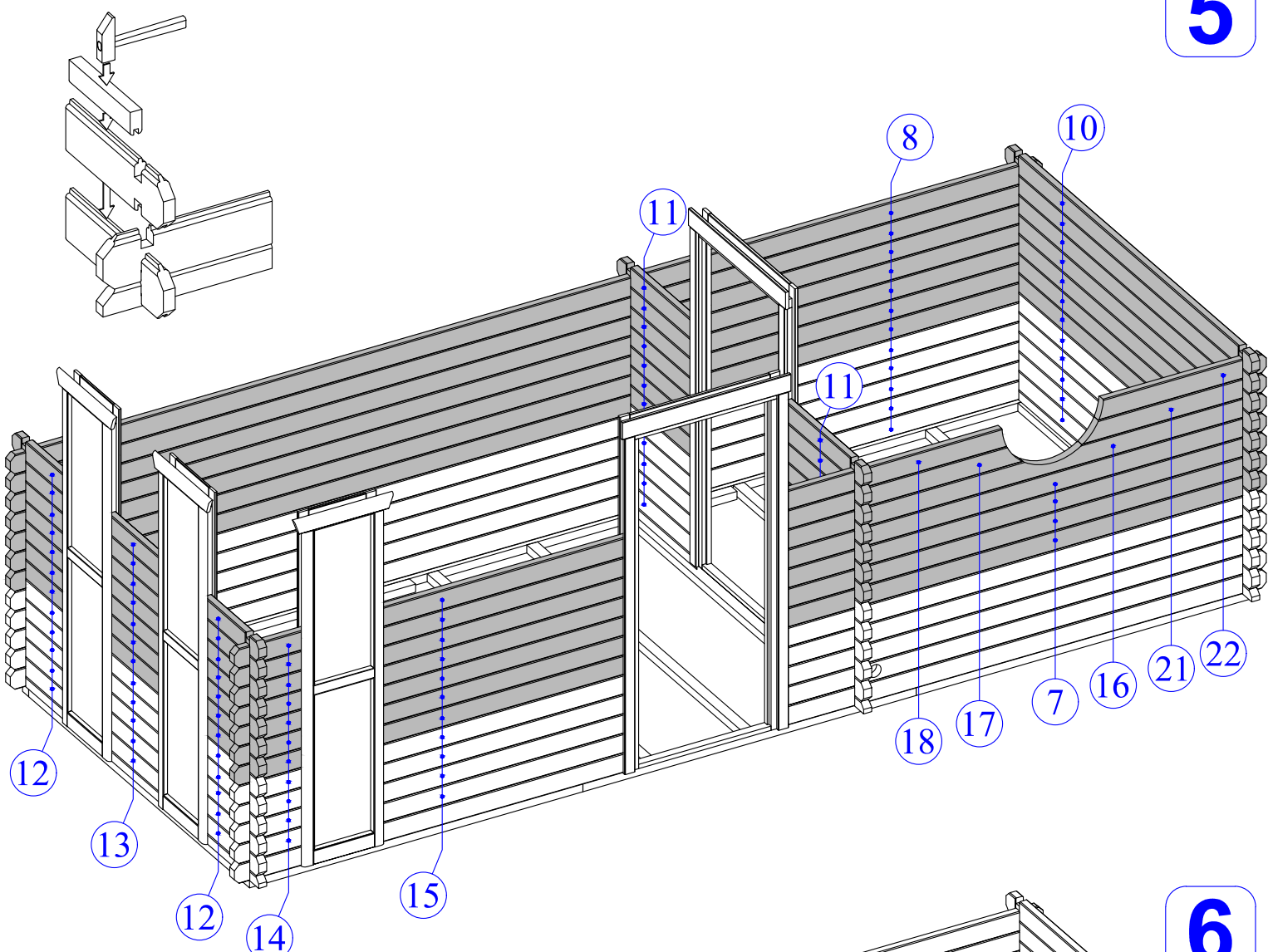

6

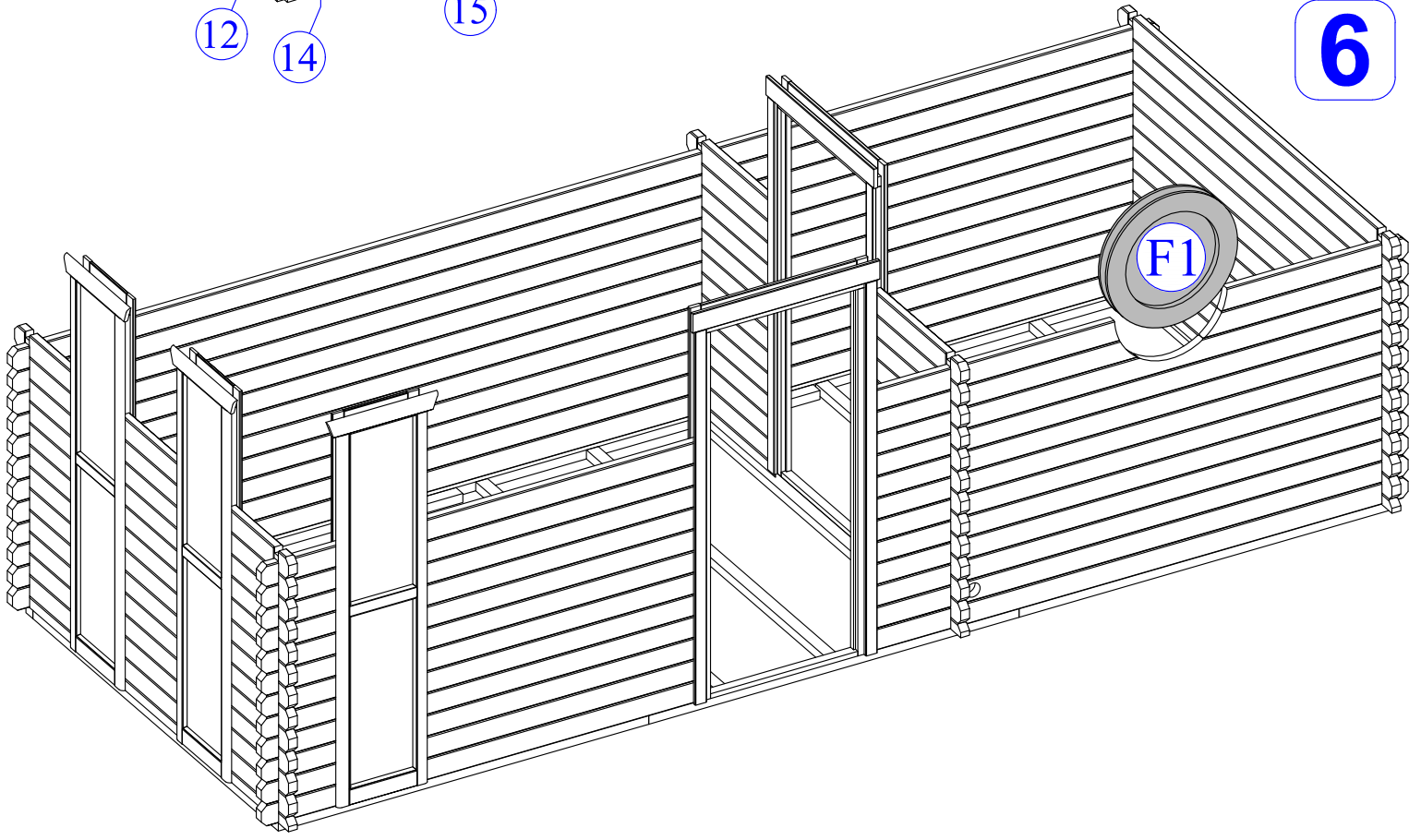

7

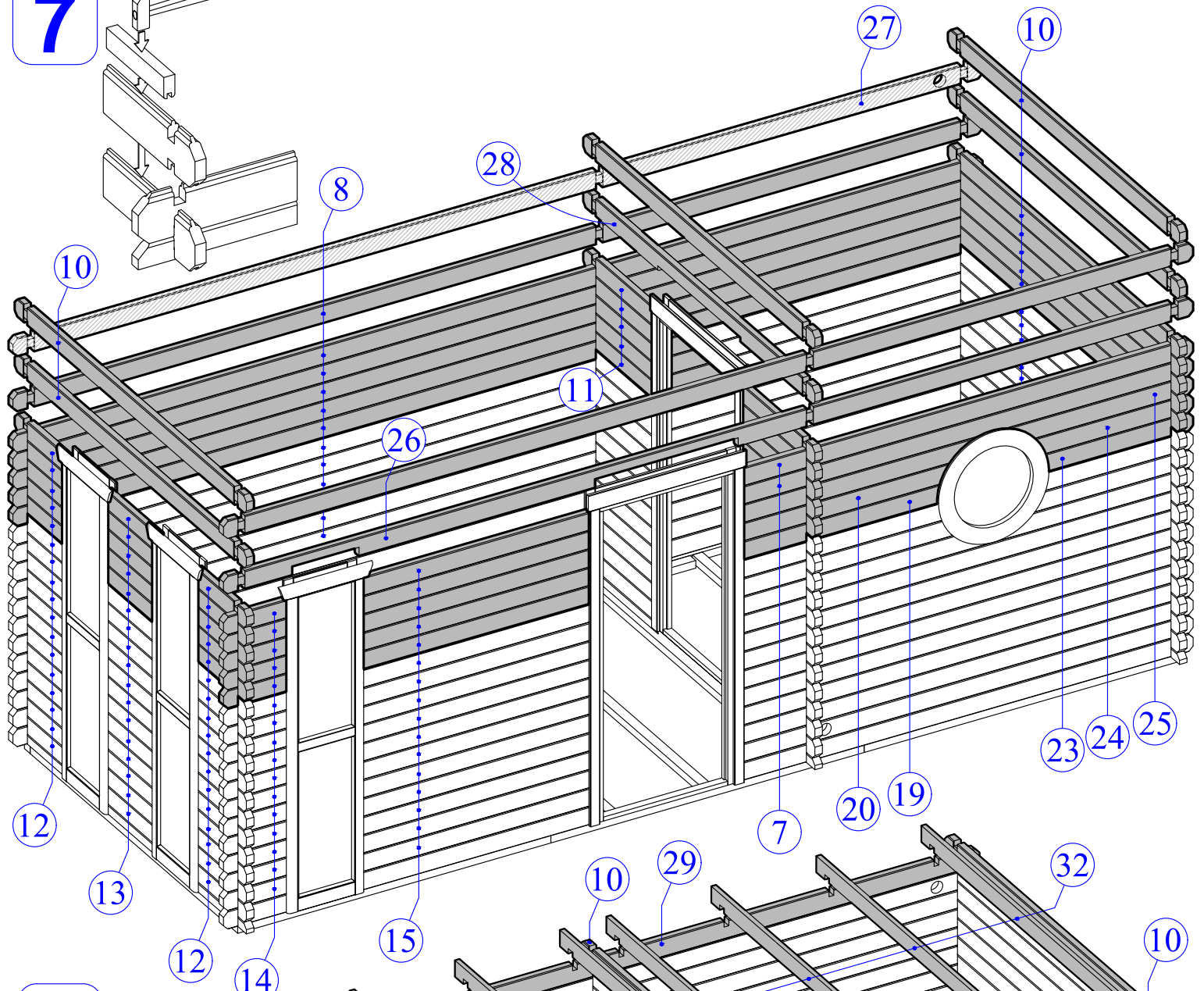
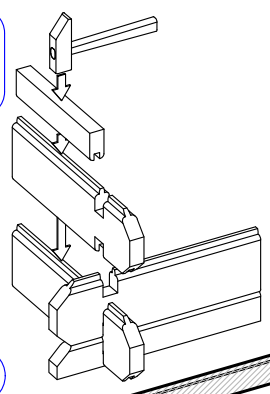

8

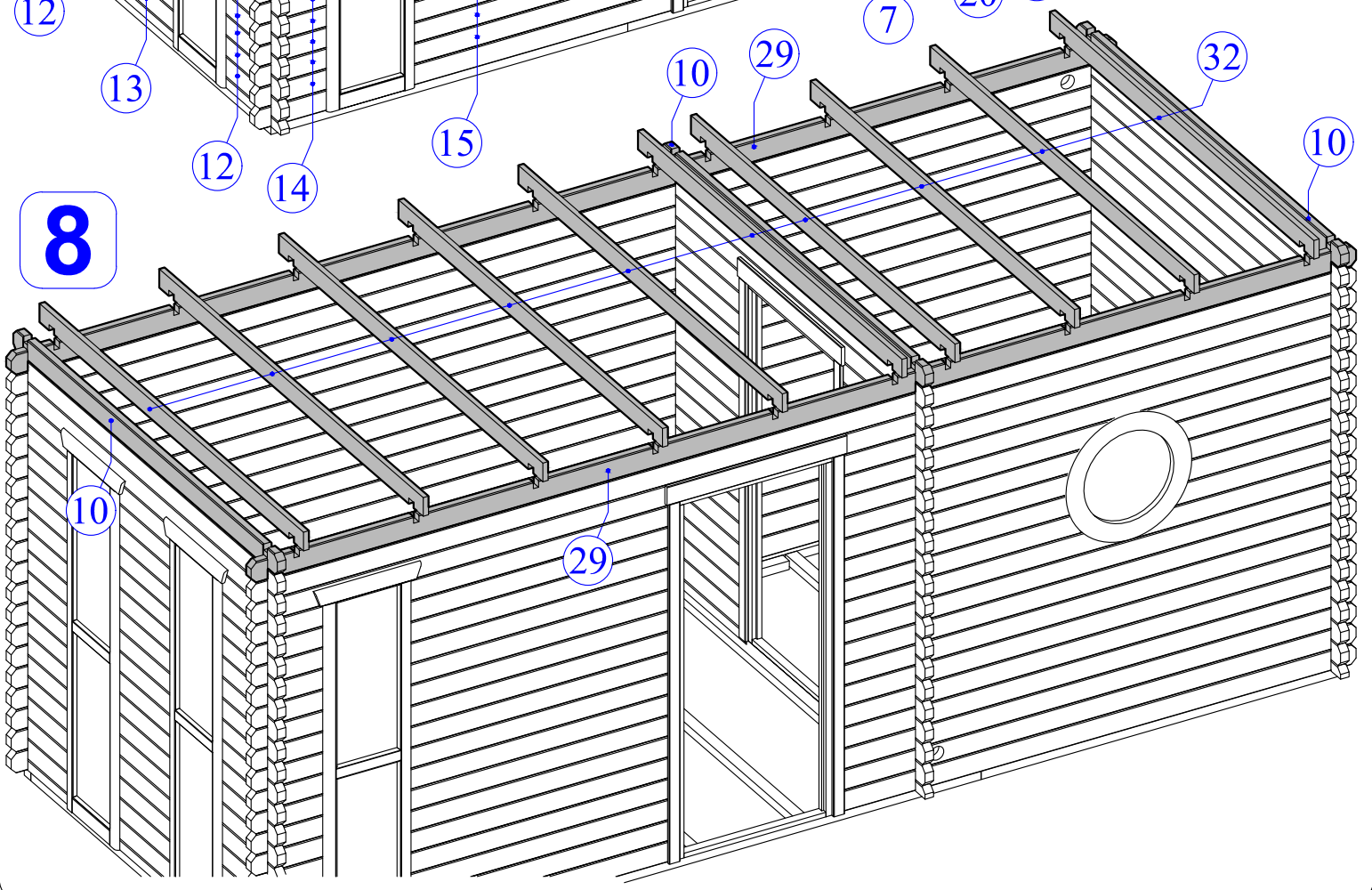

9

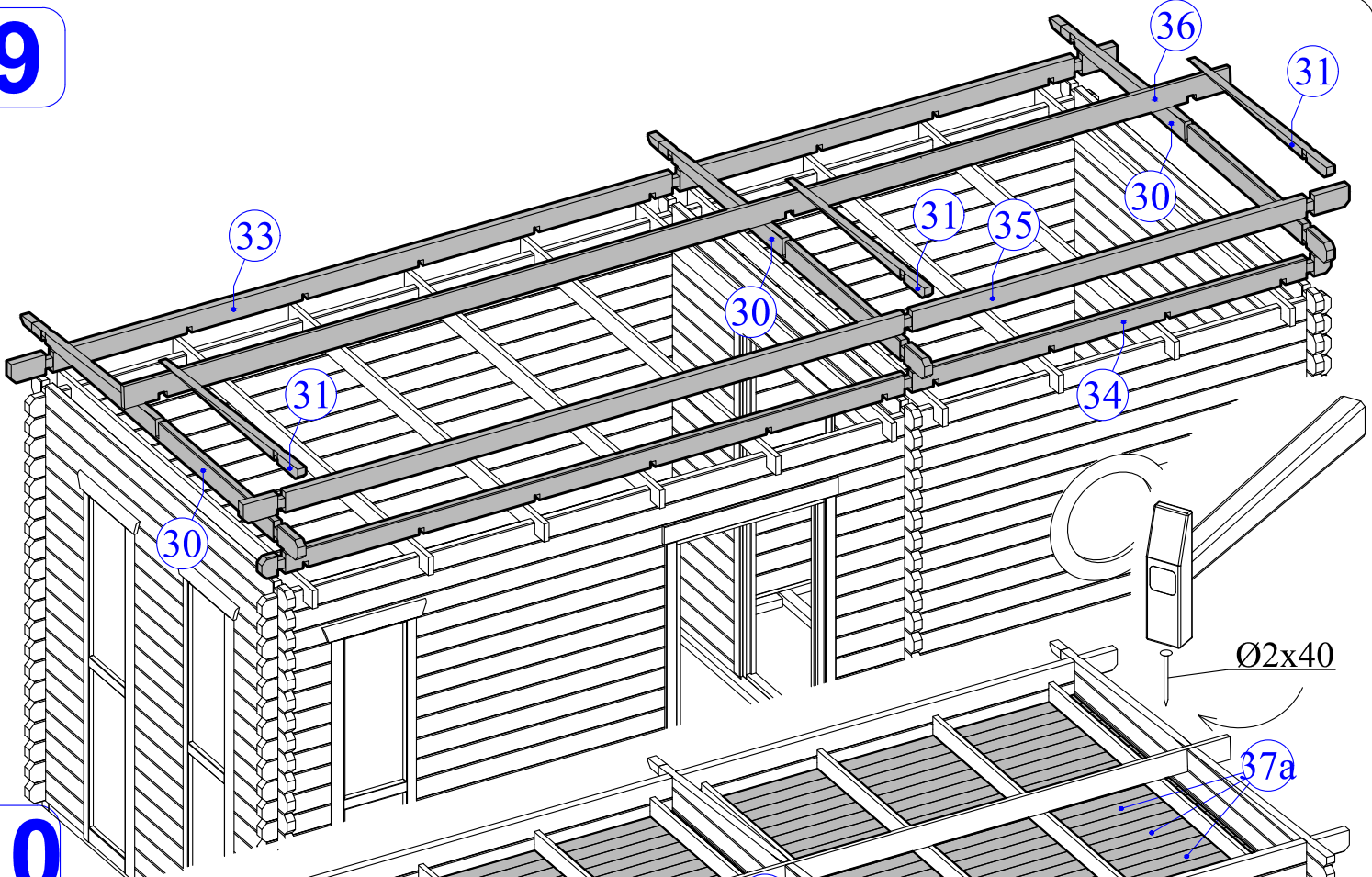

10

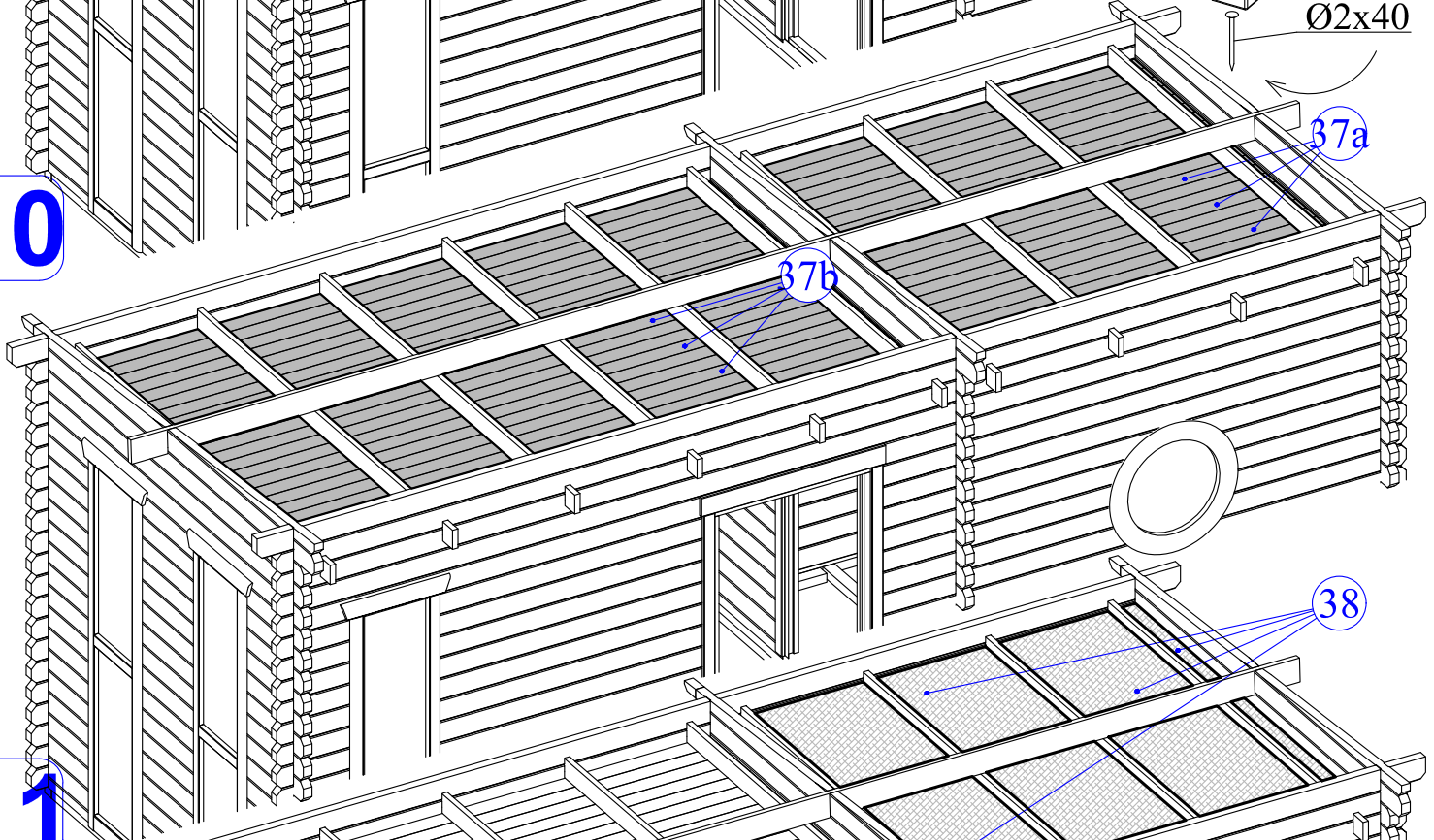

11

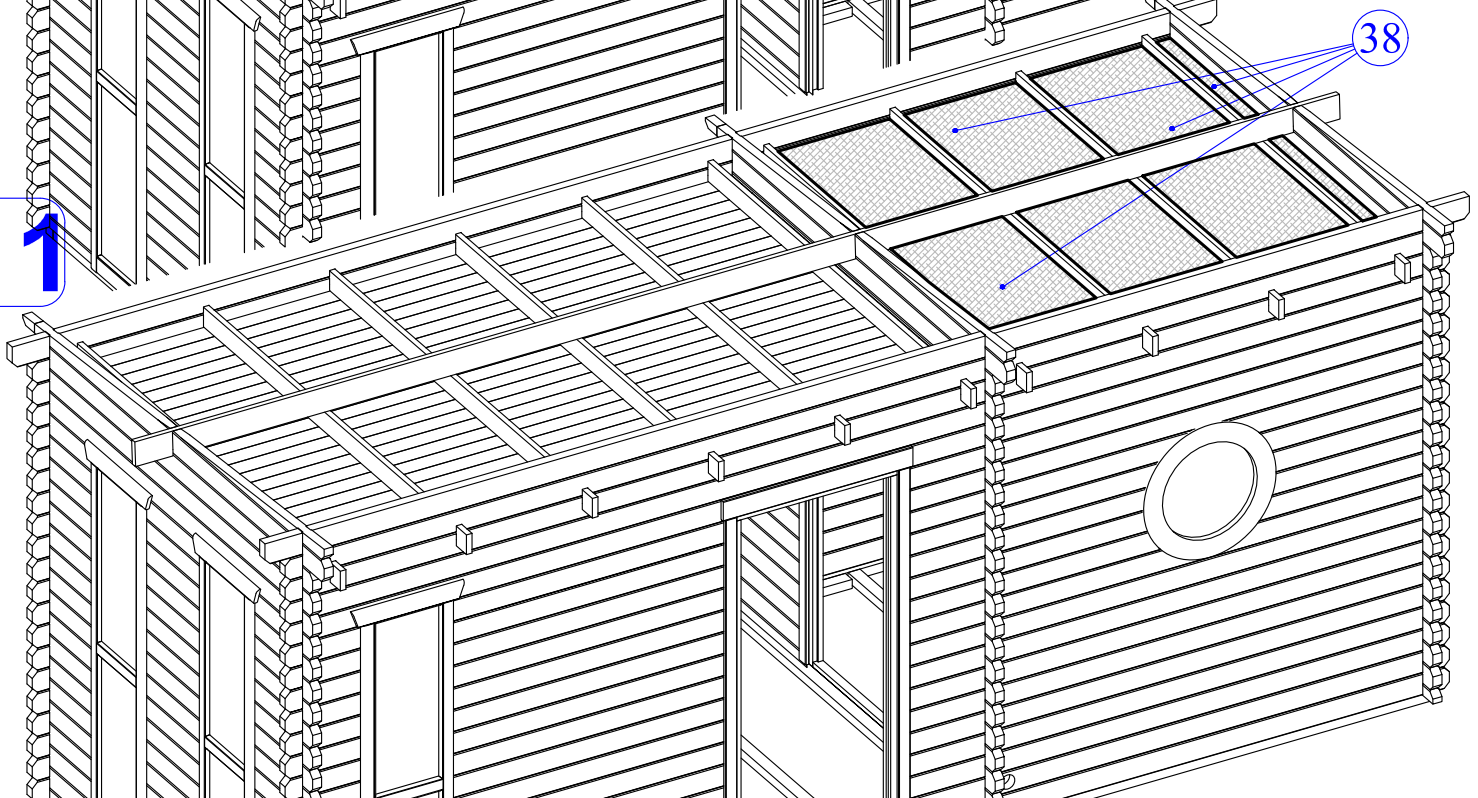

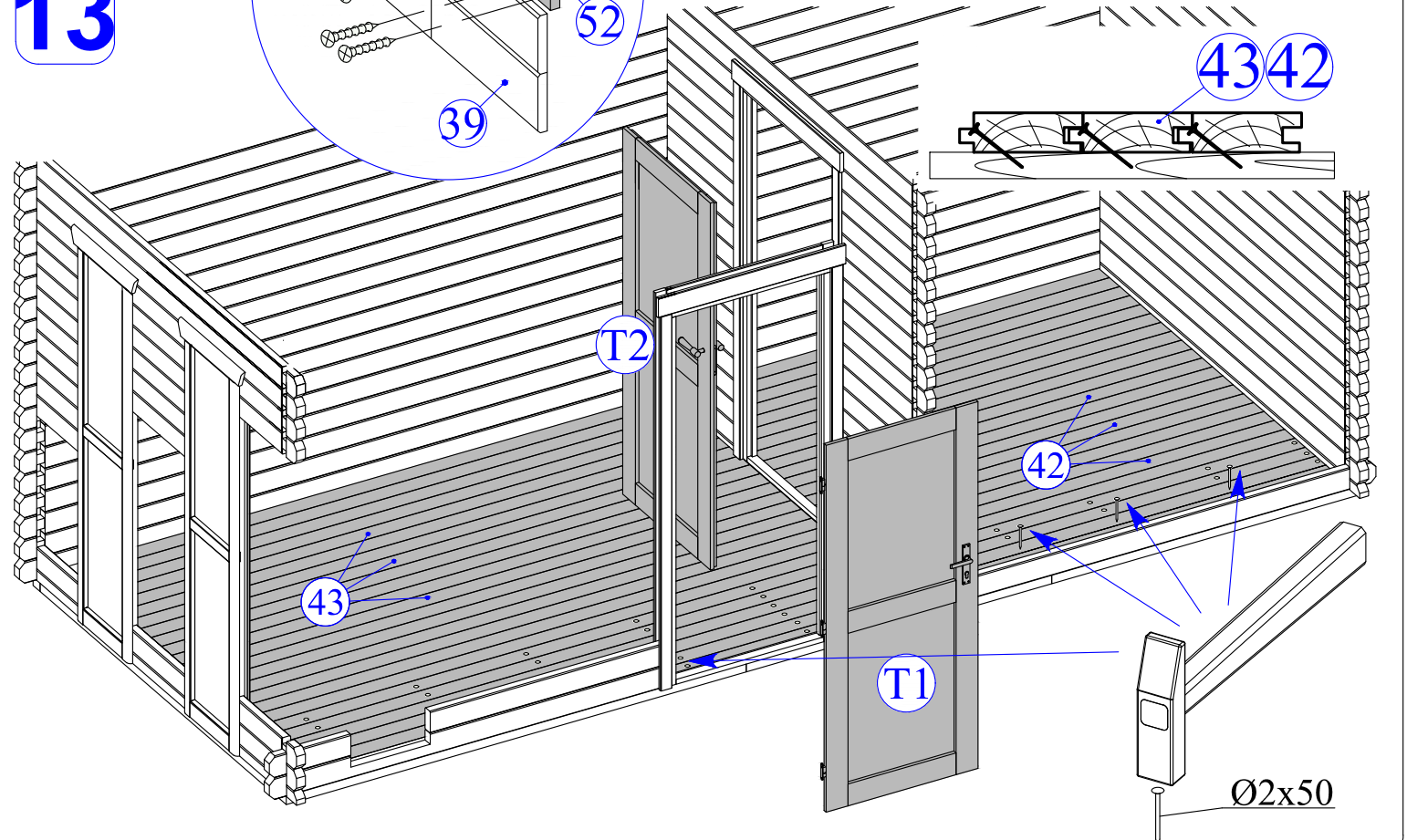
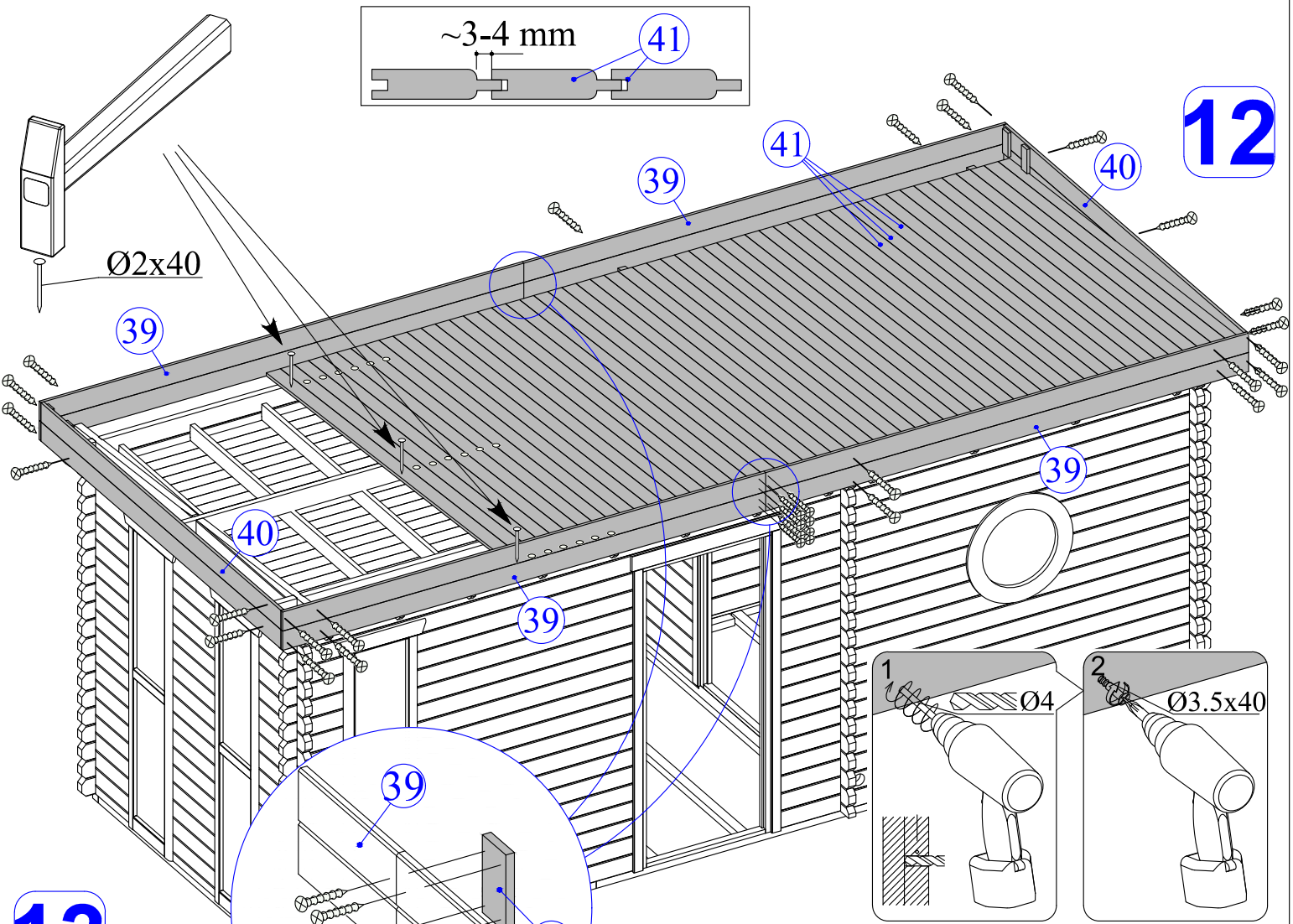

12

13

T2

T1

43 42

42

43

39

39

39

41

40

40

39

~3-4 mm

41

Ø2x50

Ø2x40

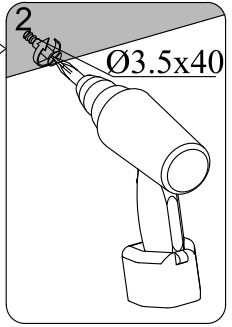
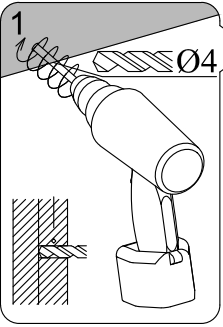

Änderung zur Montage vom Dachrinnenset.
Changes to installation of roof gutters



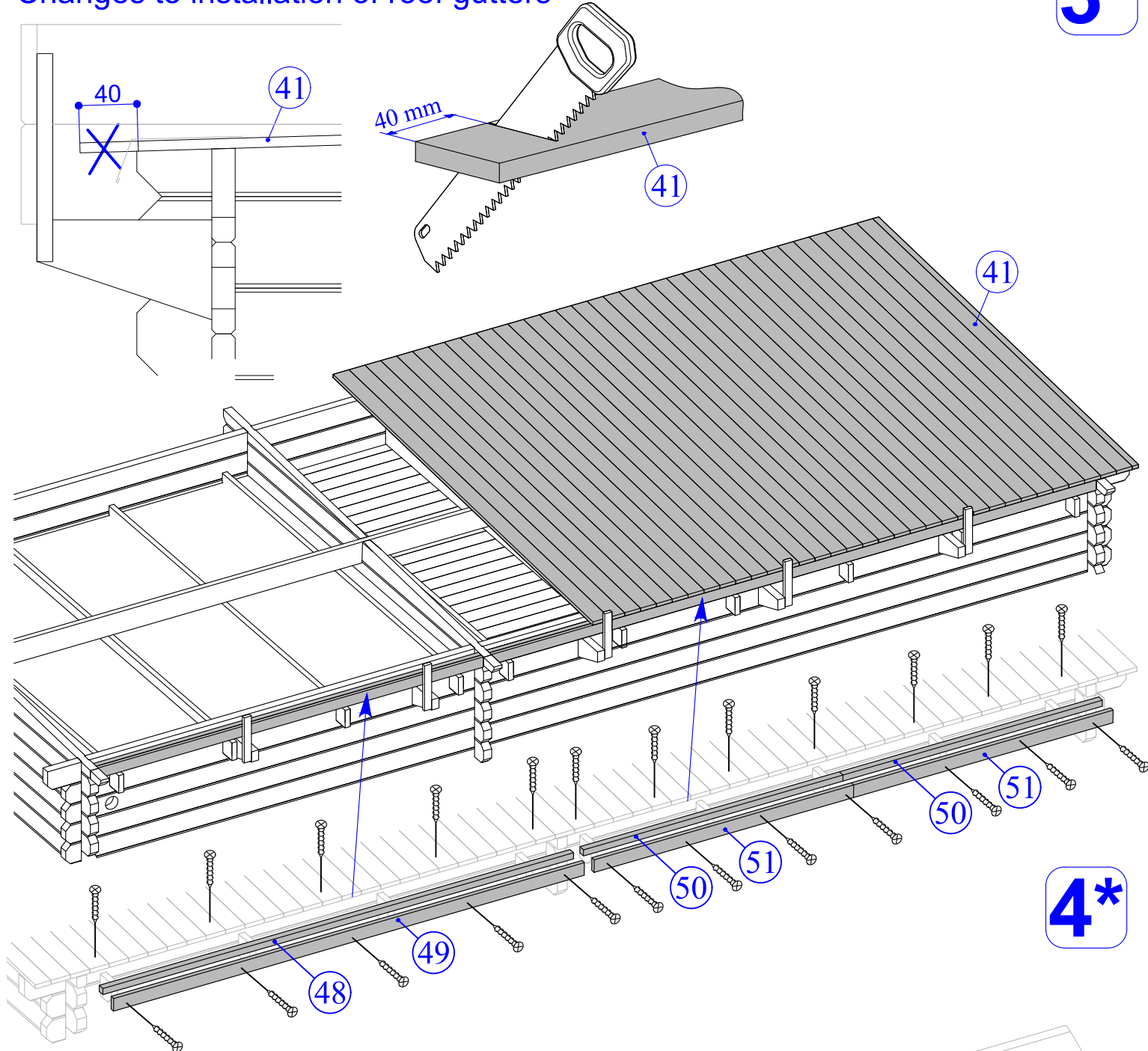



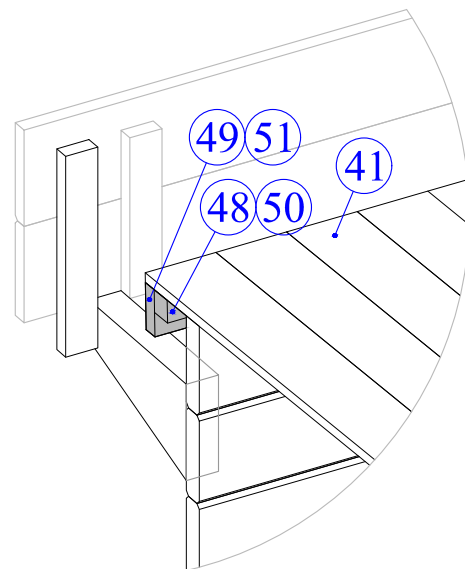
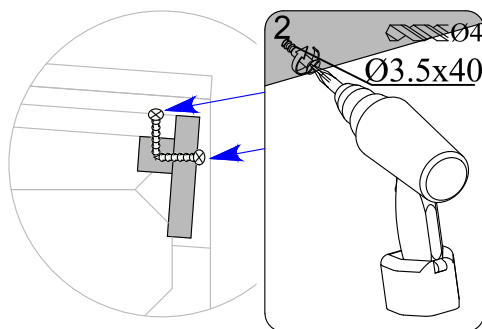
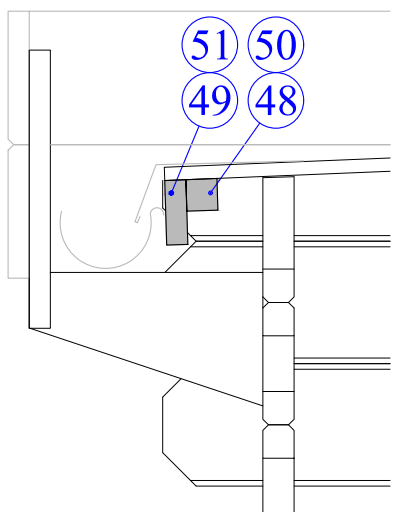

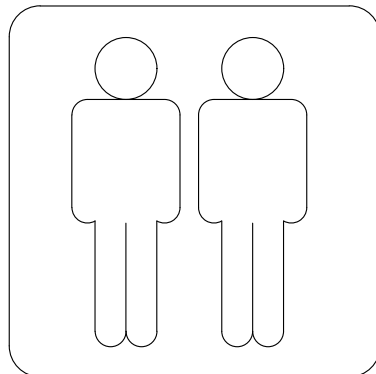
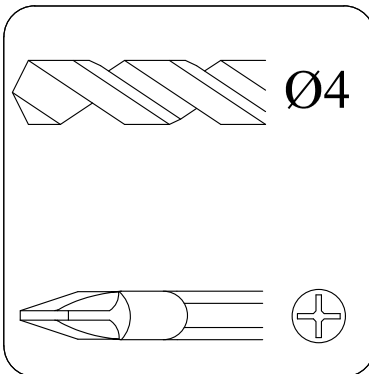
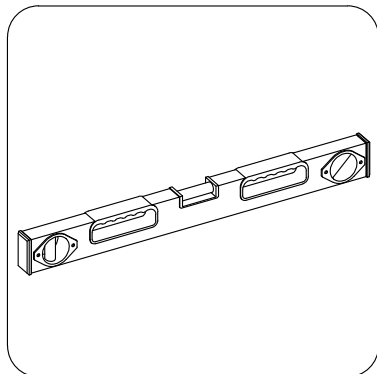
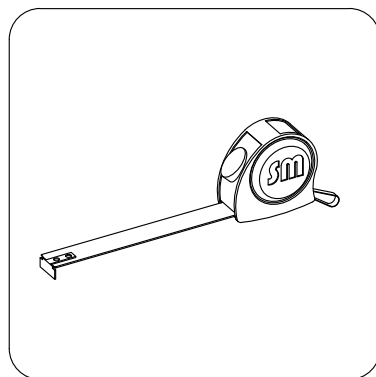
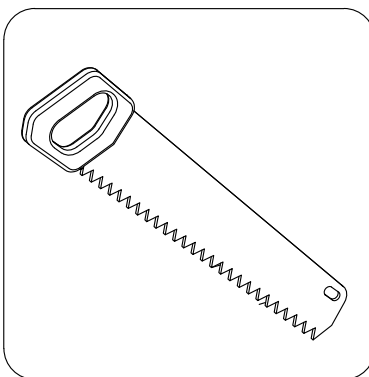
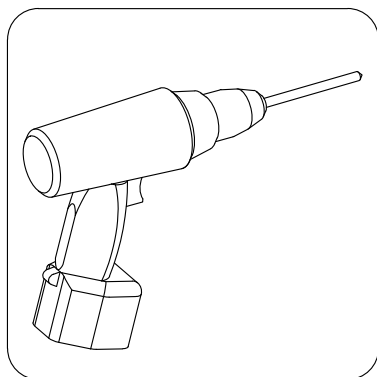
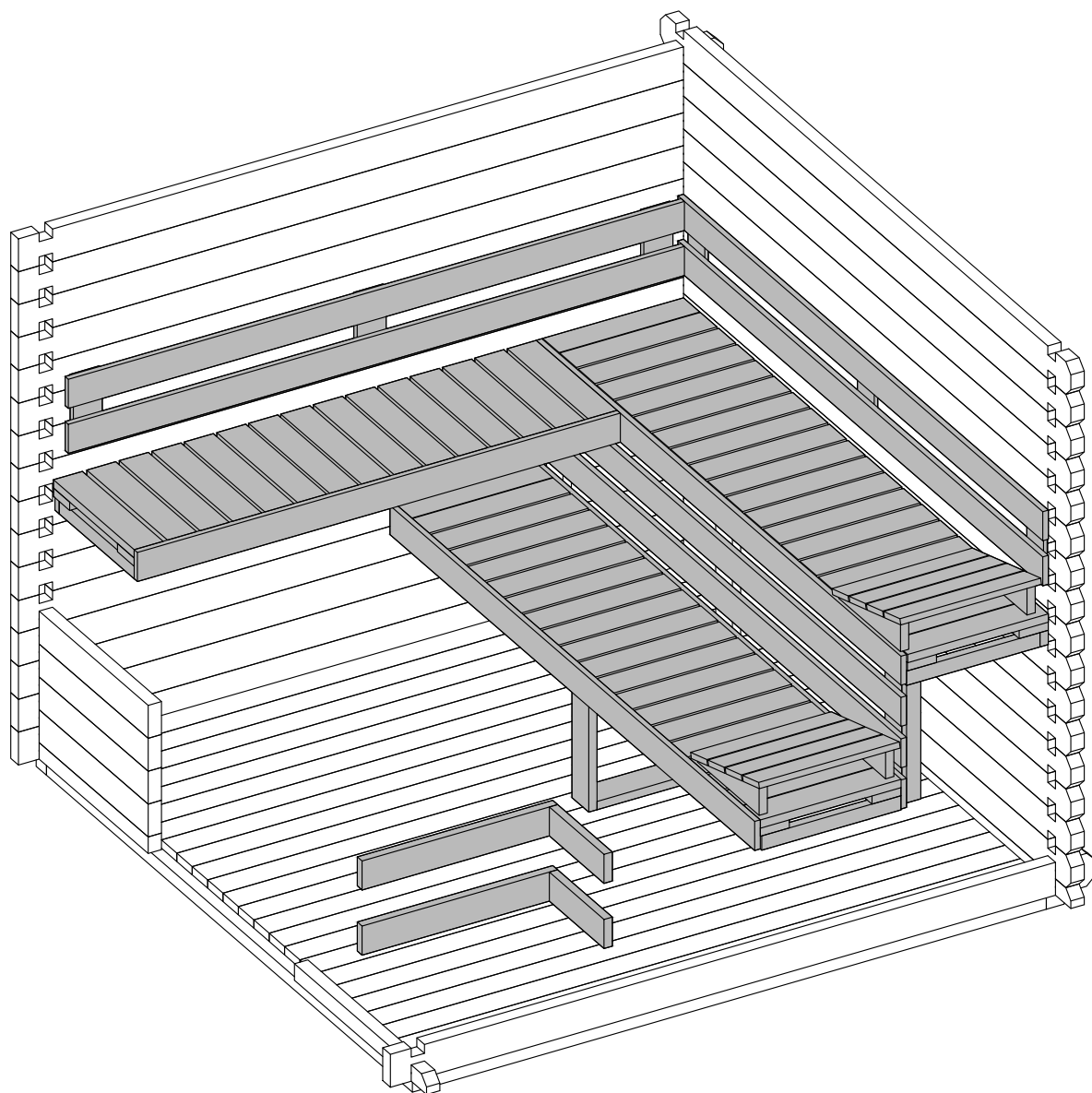

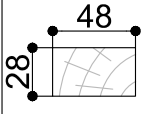
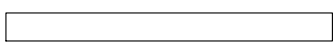
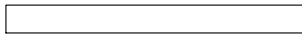
3*



4*

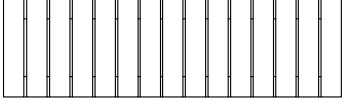
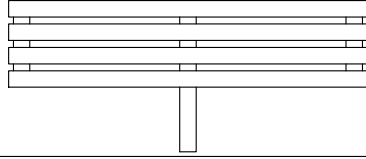
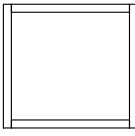
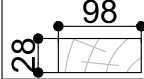
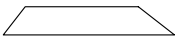
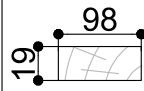
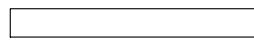

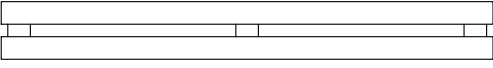
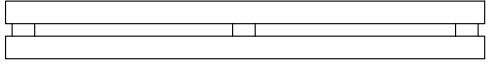
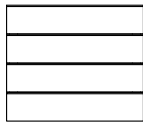
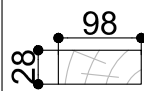
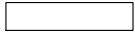

Dim.	Skizze/Sketch	Pos.	Länge/length (mm)	Stck./Total	Name	Ref.
		①	2135 (1070x2)	1	Latten Lath	287107
		②	1500	1		287108
		③	575	2		287110
		④	440	1		287112
		⑤	397	2		287109
		⑥	600	2		287111
		⑦	600 x 2135	2	Bank Bench	287113
		⑧	475 x 1500	1	Bank Bench	287114
		⑨	516 x 2135	1	Bank Bench	287115
		⑩	430 x 590	1	Unterstützung Bench support	287116
		⑪	595	1	Stützbalken Support	287124
		⑫	2135	1	Abdeckbrett Cover board	287122
		⑬	1500	1	Abdeckbrett Cover board	287123
		⑭	250 x 2135	1	Rückseite brett Backrest	287118
		⑮	250 x 2097	1	Rückseite brett Backrest	287119
		⑯	300 x 475	2	Pad Pad	287117
		⑰	320	2	Rückseite brett Cover board	287120
		⑱	660	2	Rückseite brett Cover board	287121

Ø4.5 x 90 -17

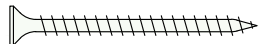

Ø3.5 x 45 -69



Ø3.5 x 25 -36



-6

1

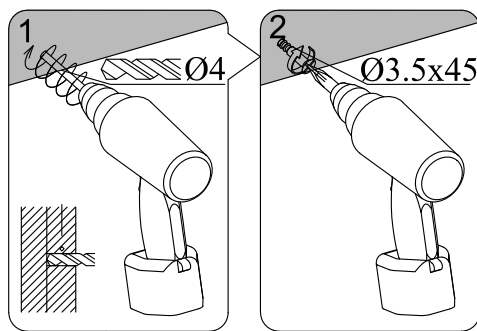
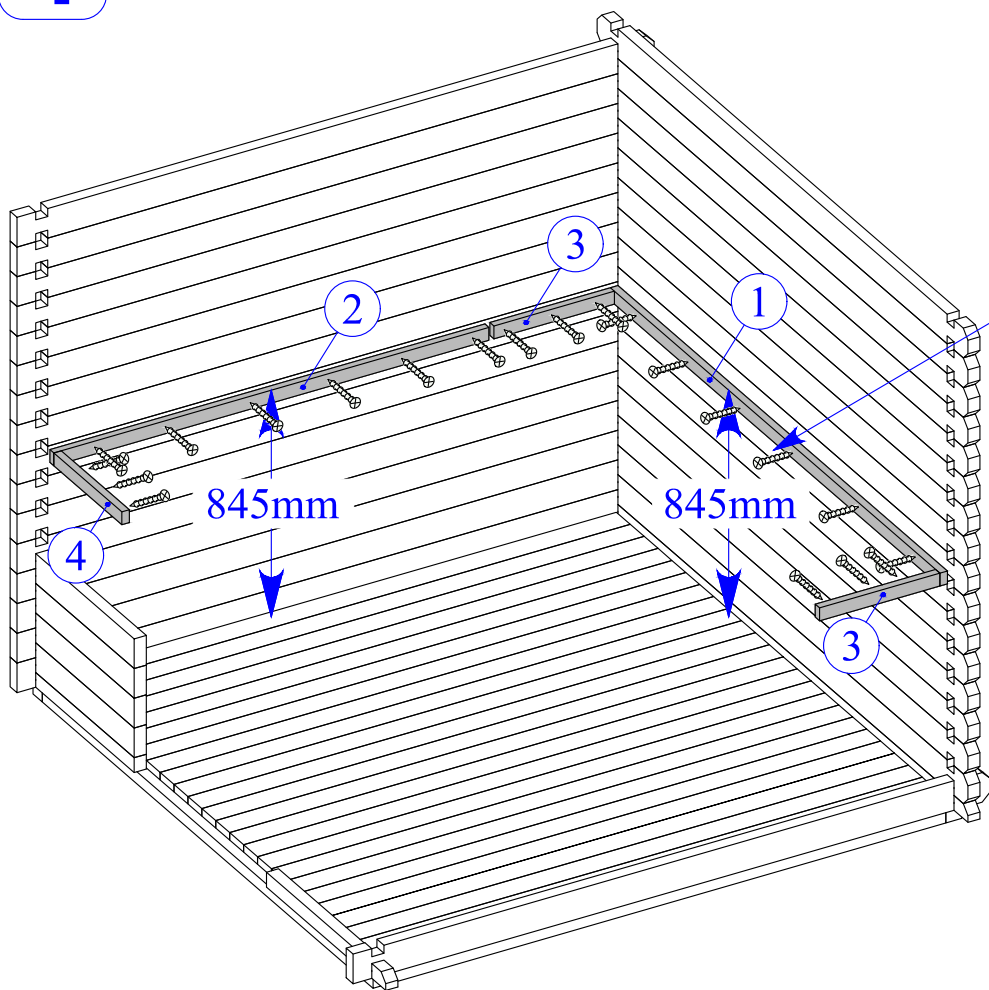

2

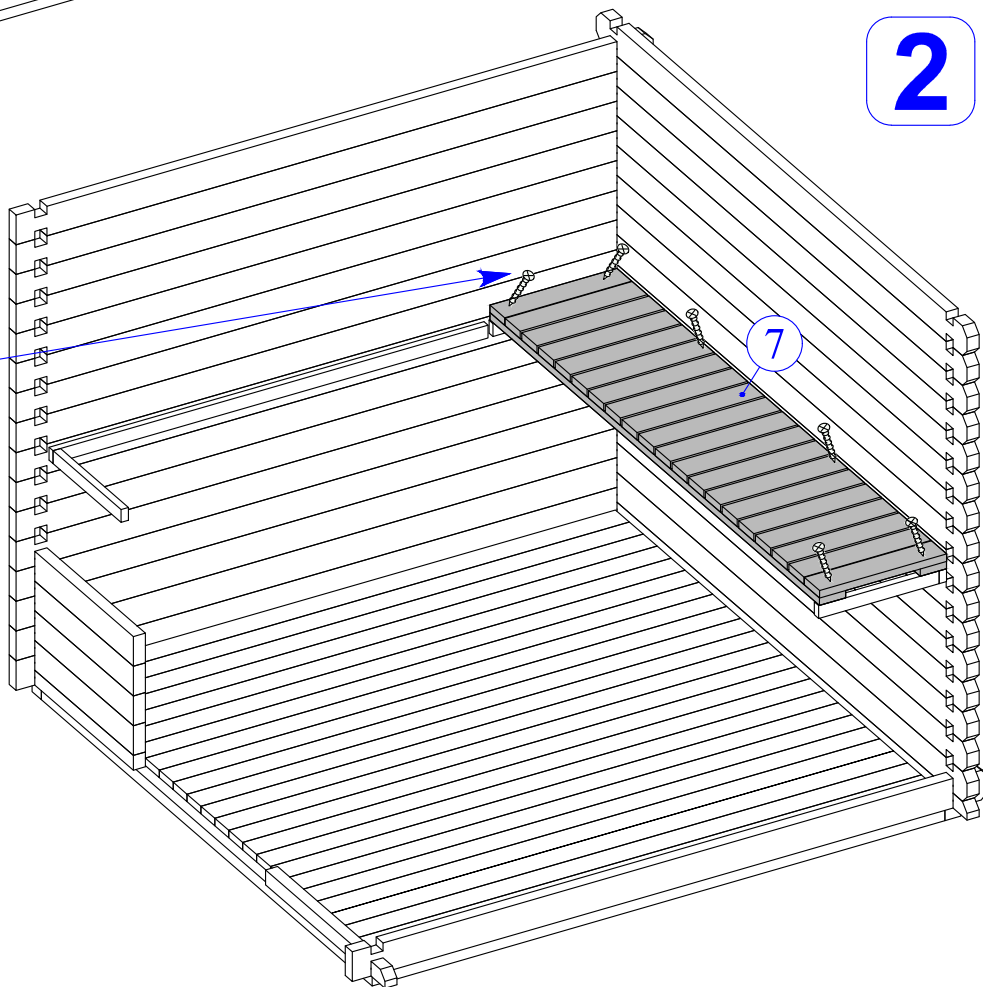
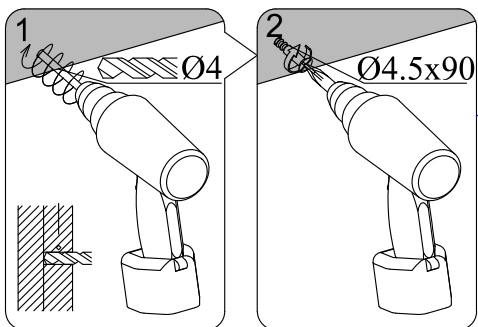

3

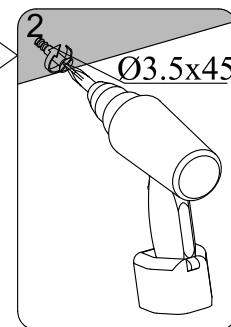
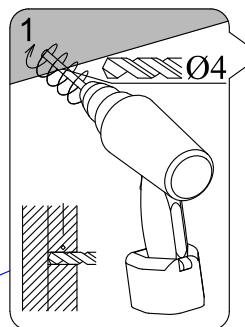
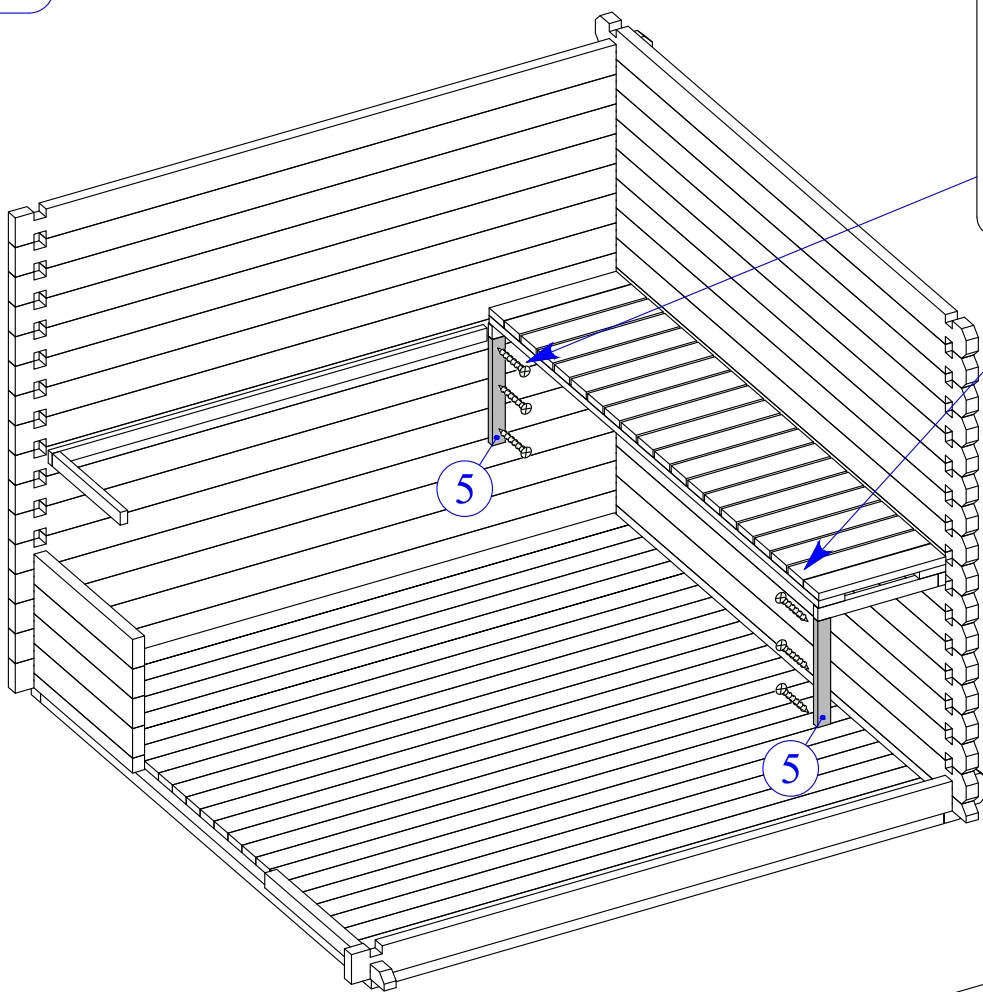

4

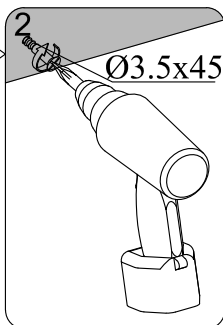
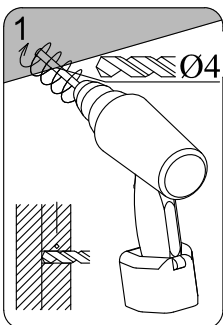
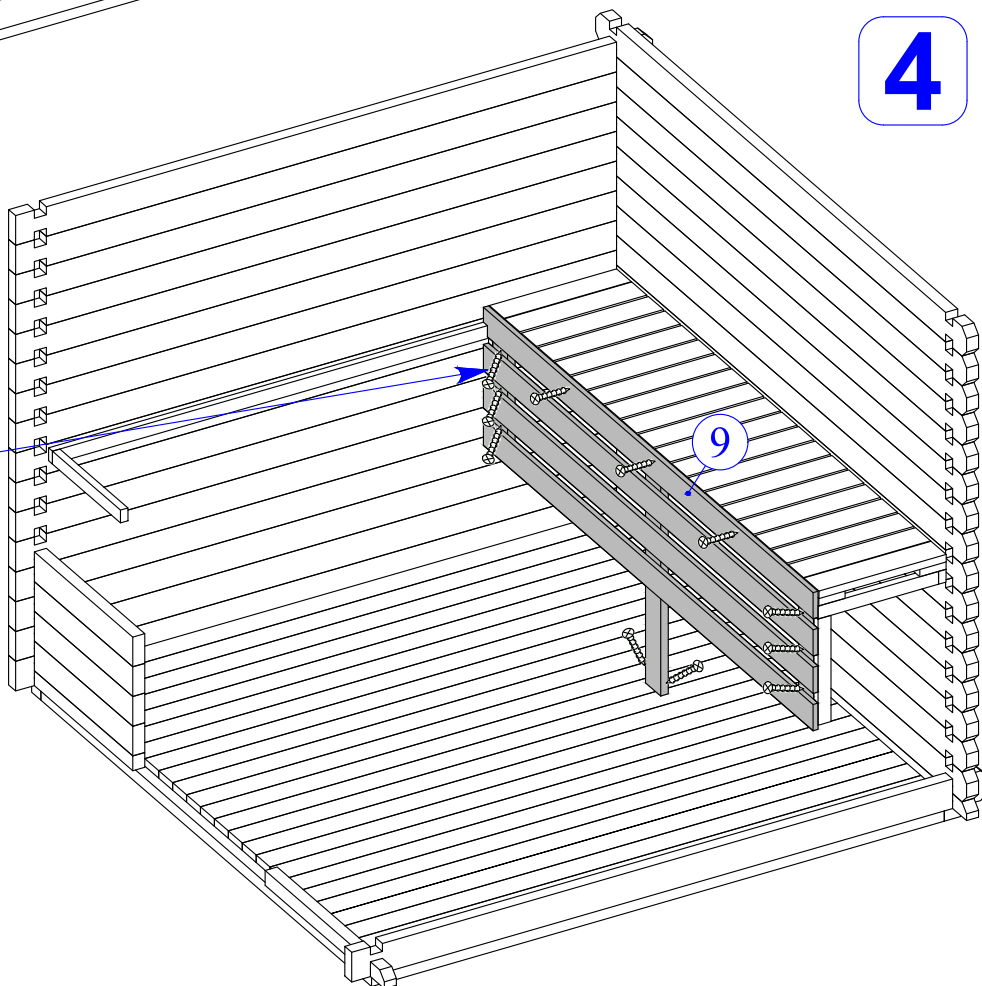

5

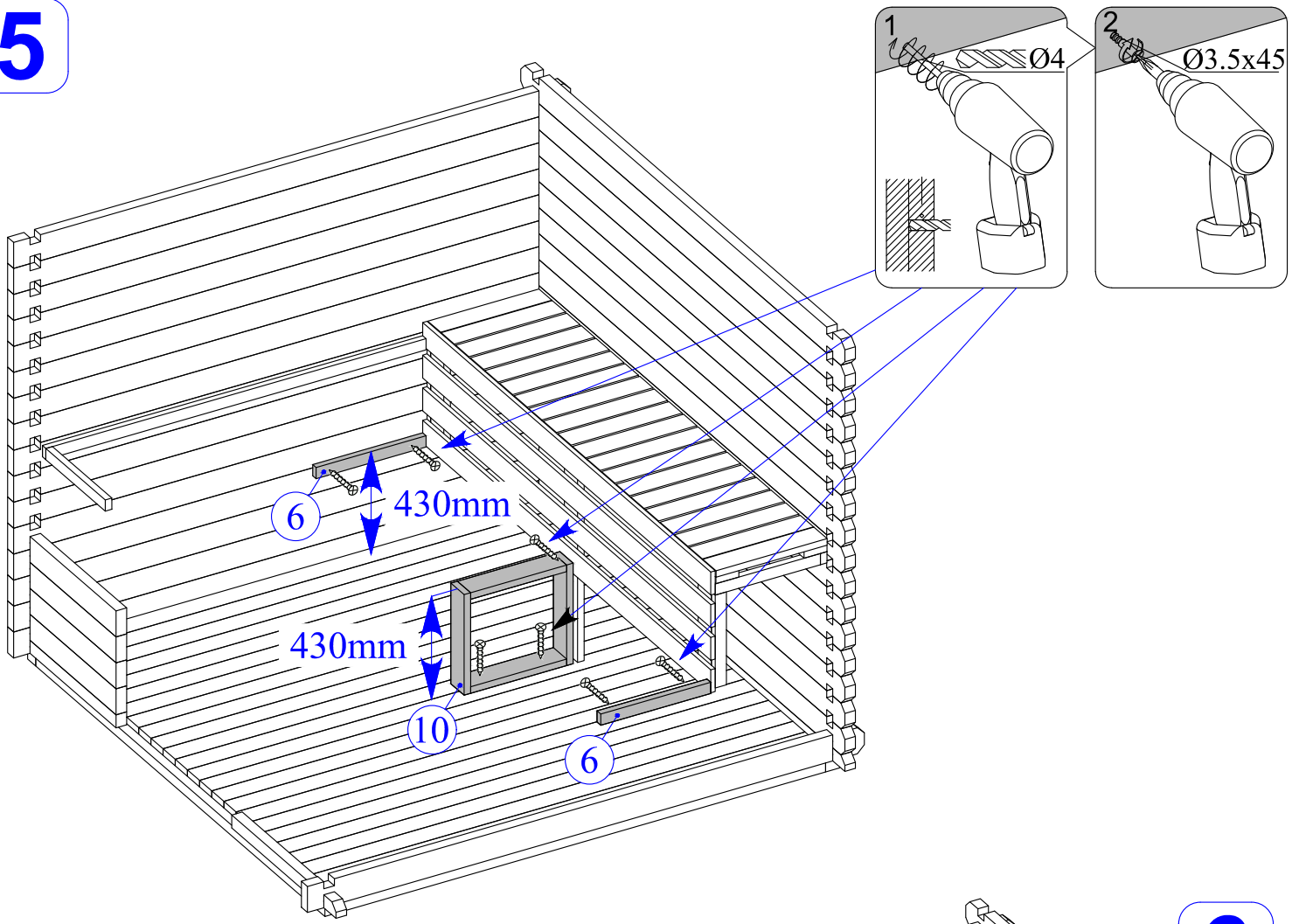

6

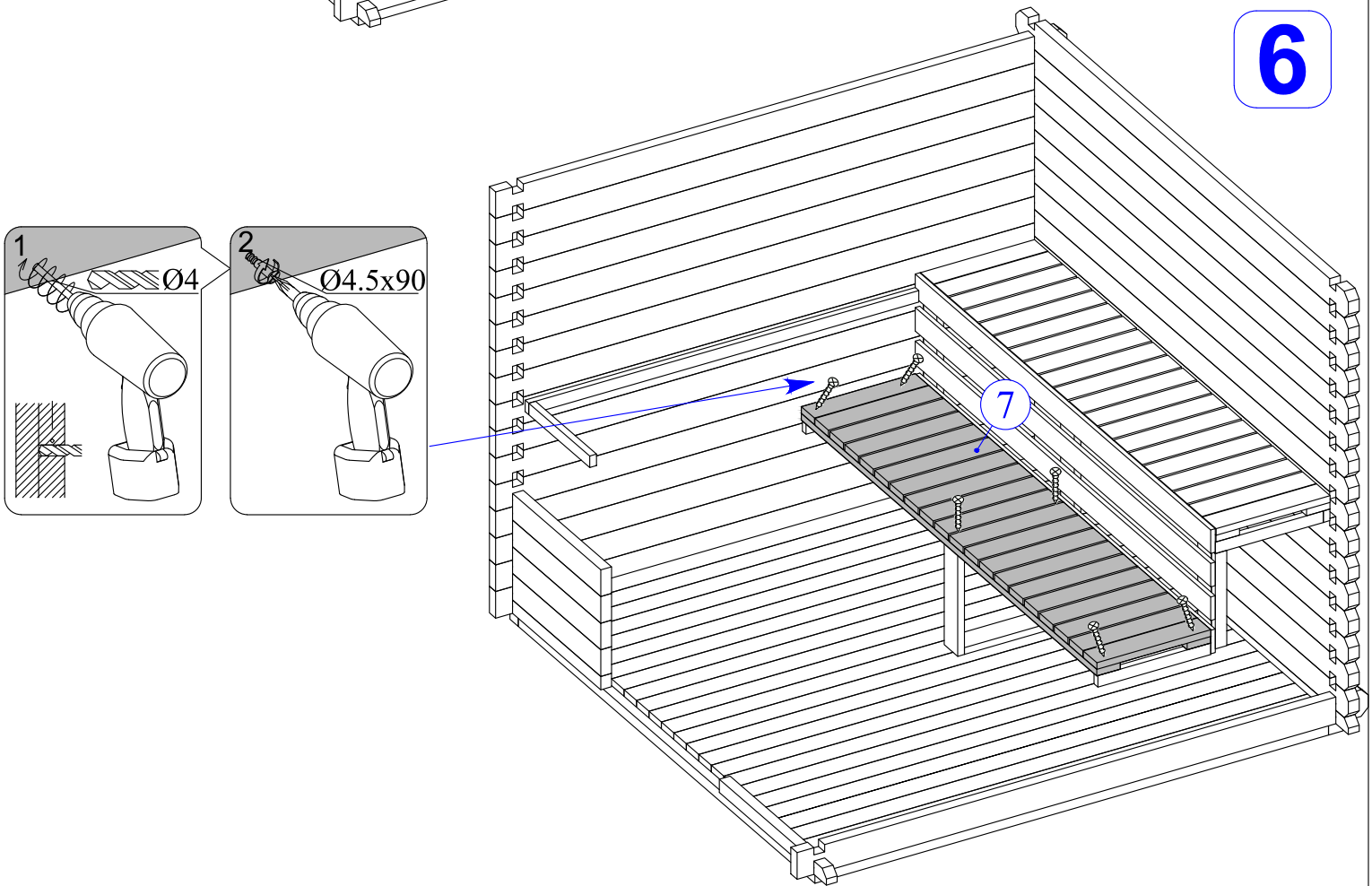

7

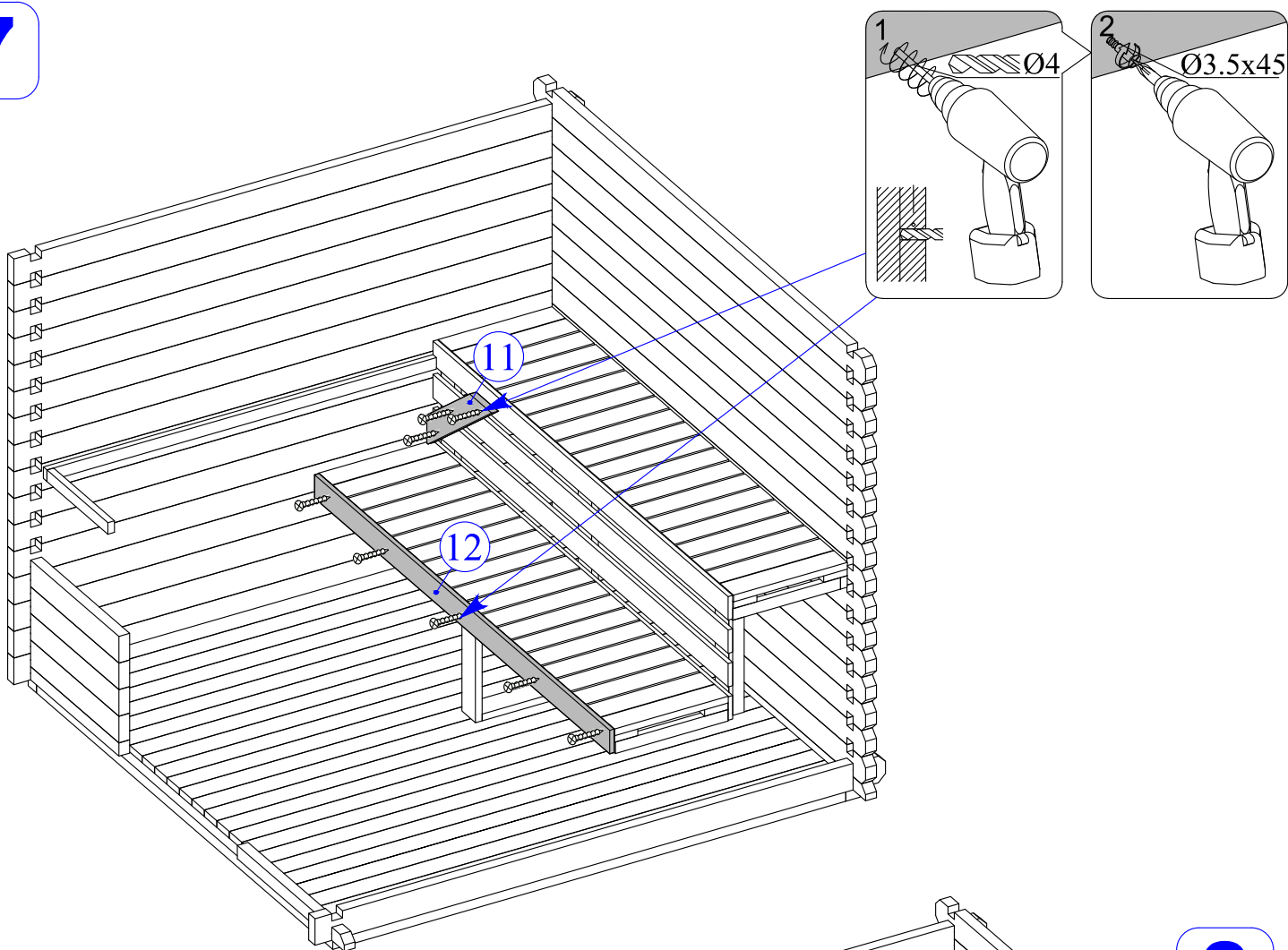

8

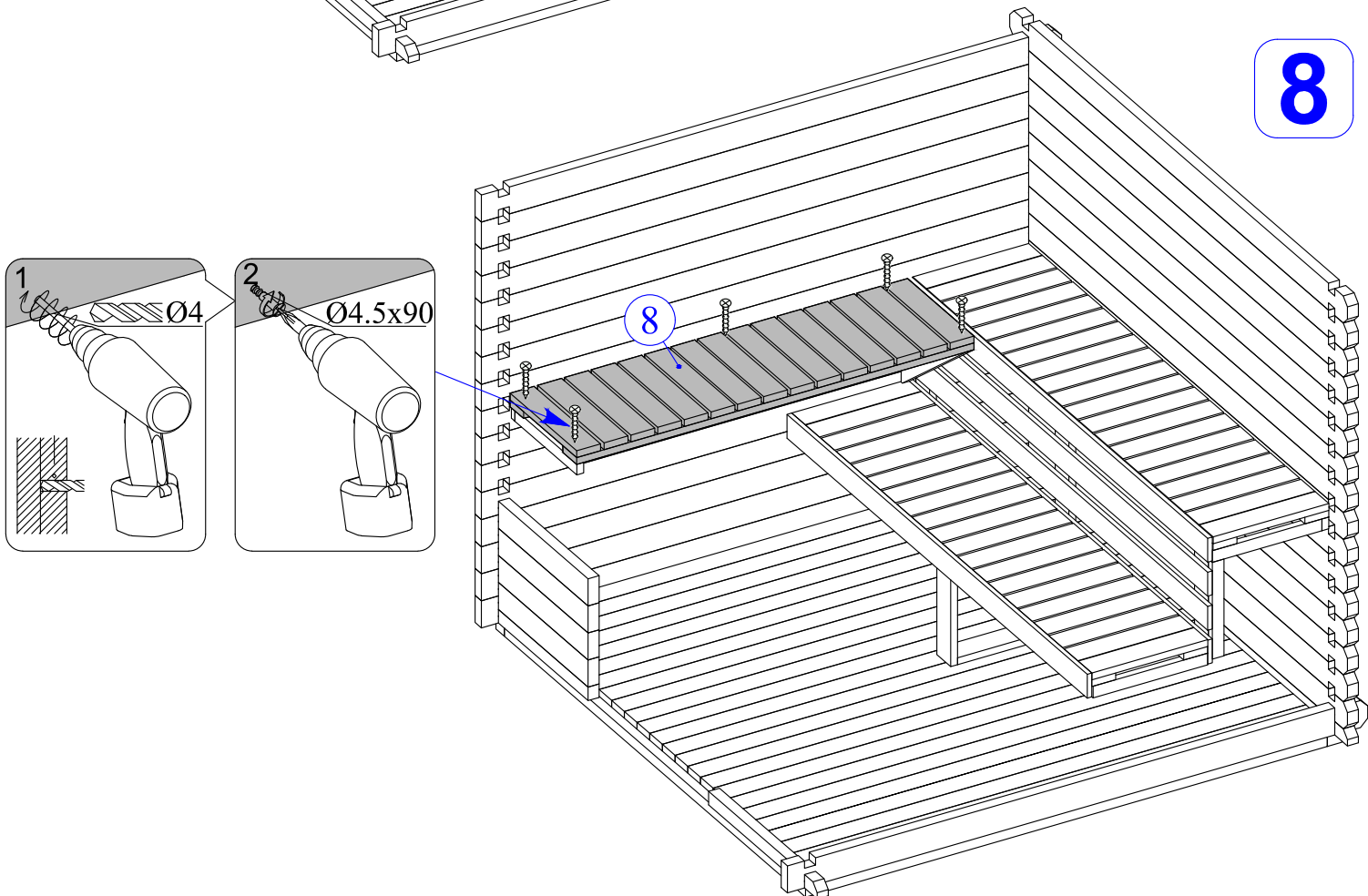

9

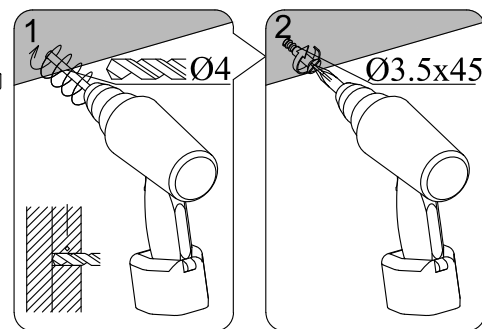
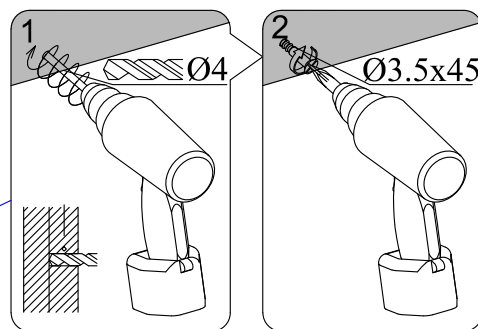
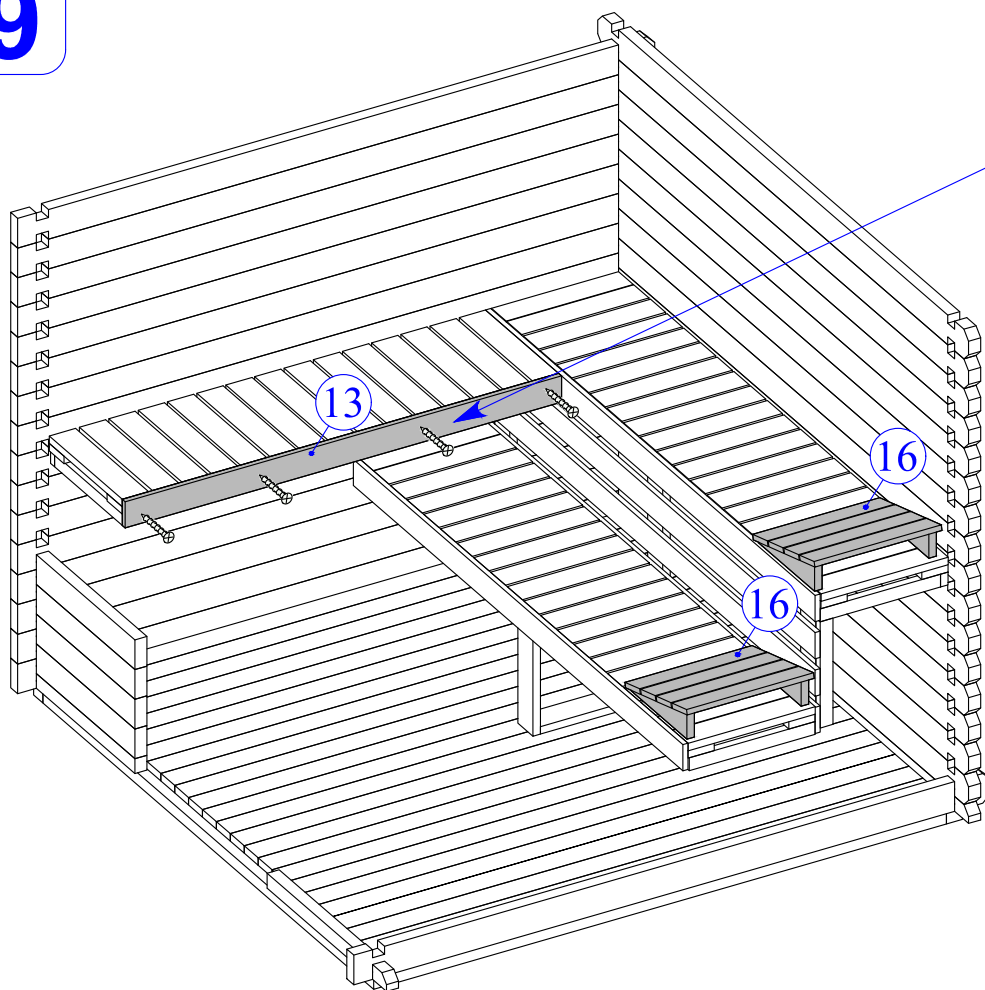

10

