

→||←40mm

5,8 x 3,9

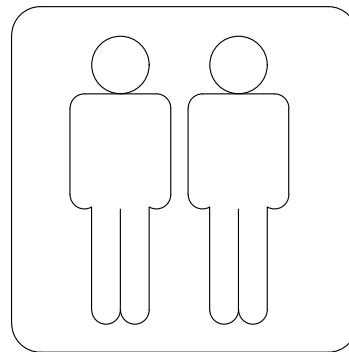

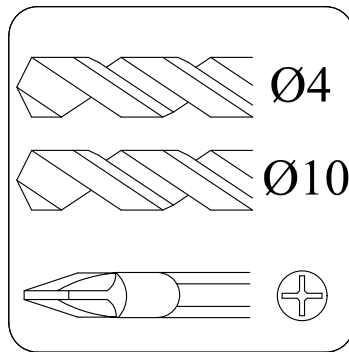

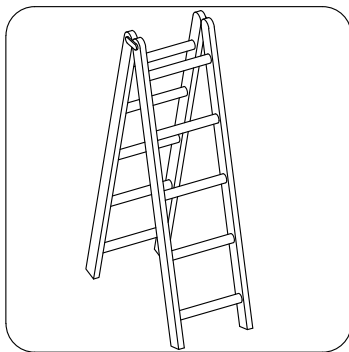
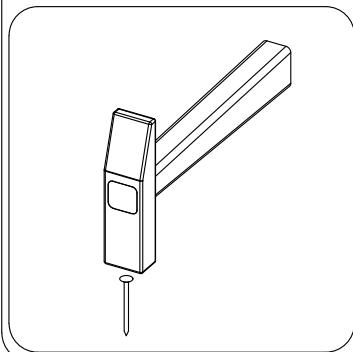
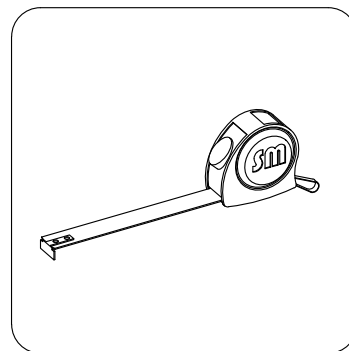
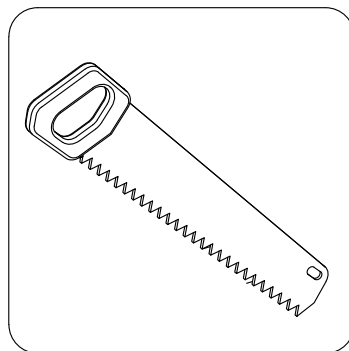
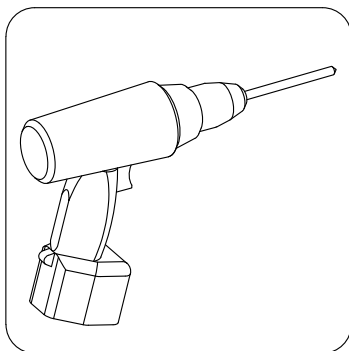
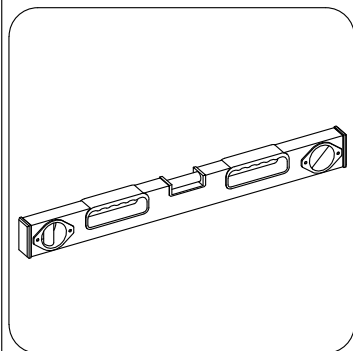
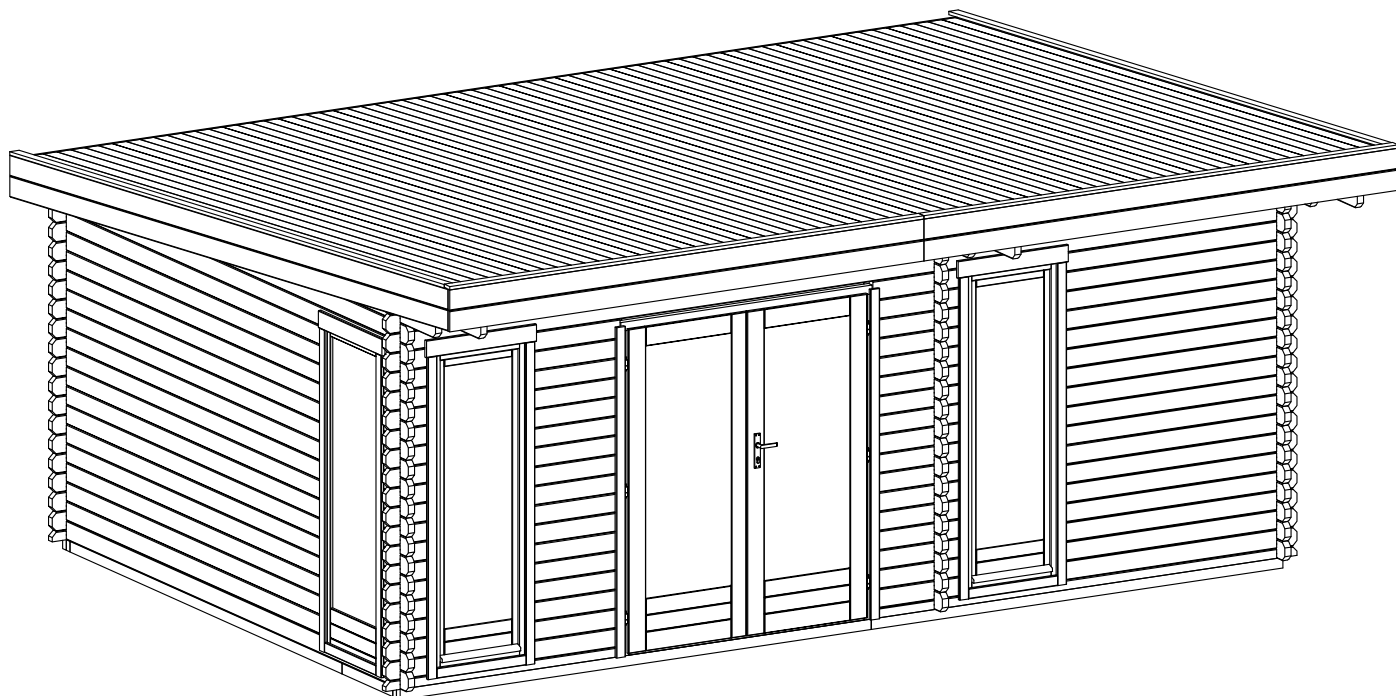

**40212**

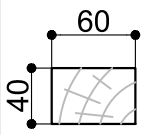
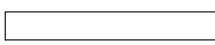
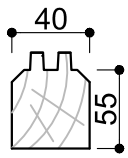

→||←40mm

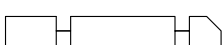
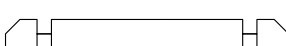
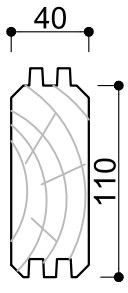
## SPECIFICATION 5,8 x 3,9

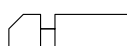
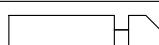
**40212**

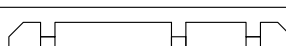
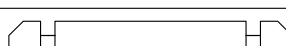
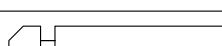
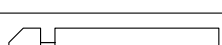
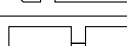
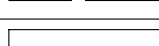
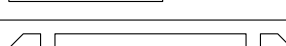
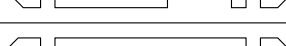

Dim.	Skizze	Pos.	Länge (mm)	Stck.	Name	Ref.
		①	3000	14	Fundamentbalken Lambourdes Foundation beam	283039
		②	2460	10		...
		②a	2080	2		...
		③	720	4		...
		④	400	6		283084
		④a	475	12		...
		⑤	5800	1	Zurück Brett Madrier arrière Back board	400299
		⑥	1490	1	Front Brett Madrier avant Front board	400300
		⑦	2700	1	Front Brett Madrier avant Front board	400301
		⑧	2400	1	Front Brett Madrier avant Front board	400302
		⑨	3900	20	Seiten Brett Madrier latéral Side board	400303
		⑩	3900	1	Seiten Brett Madrier latéral Side board	400304
		⑪	285	51	Front/Zurück Brett Madrier avant/arrière Front/Back board	400039
		⑫	515	18	Front Brett Madrier avant Front board	400131
		⑬	1390	18	Front Brett Madrier avant Front board	400305
		⑭	5800	23	Zurück Brett Madrier arrière Back board	400306
		⑮	2400	19	Front Brett Madrier avant Front board	400307
		⑯	2980	16	Seiten Brett Madrier latéral Side board	400255
		⑰	1495	17	Front Brett Madrier avant Front board	400308
		⑱	570	17	Front Brett Madrier avant Front board	400309
		⑲	570	17	Front Brett Madrier avant Front board	400310
		⑳	3900	1	Seiten Brett Madrier latéral Side board	400311
		㉔	3900	1	Seiten Brett Madrier latéral Side board	400267

Alle maßen ca +/-3% / les dimensions des pièces peuvent évoluer +/- 3% / size tolerance +/- 3%

→ || ← 40mm

# SPECIFICATION 5,8 x 3,9

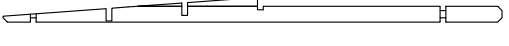
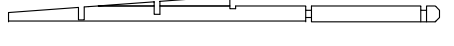
# 40212

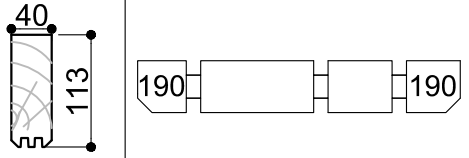
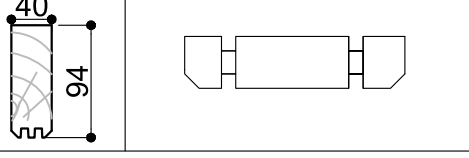
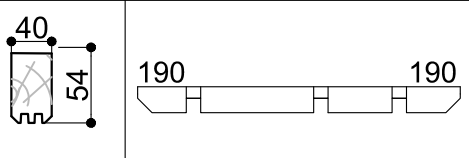
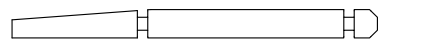
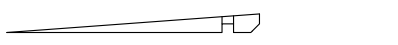
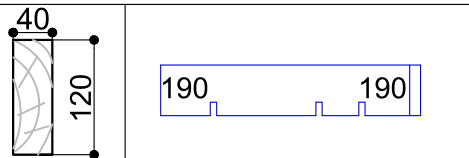
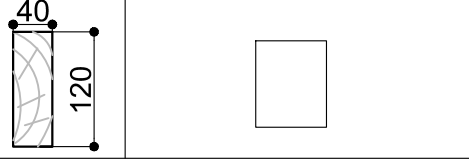
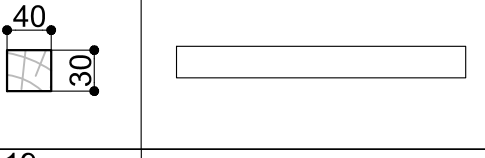
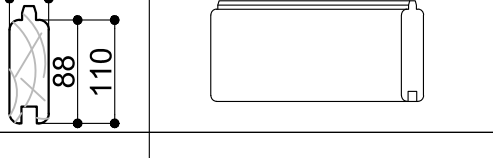
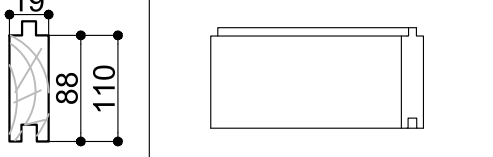





	<b>23</b>	4300	2	Seiten Brett Madrier latéral Side board	402046
	<b>24</b>	4300	1	Seiten Brett Madrier latéral Side board	402037
	<b>25</b>	2993	3	Seiten Brett Madrier latéral Side board	402038
	<b>26</b>	486	2	Seiten Brett Madrier latéral Side board	402047
	<b>27</b>	6000	2	Front/Zurück Brett Madrier avant/arrière Front/Back board	401042
	<b>28</b>	2400	1	Front/Zurück Brett Madrier avant/arrière Front/Back board	401043
	<b>29</b>	6000	1	Front Brett Madrier avant Front board	401044
	<b>30</b>	1416	3	Seiten Brett Madrier latéral Side board	402039
	<b>31</b>	877	3	Seiten Brett Madrier latéral Side board	402040
	<b>32</b>	6000	6	Front Brett Madrier avant Front board	404057
	<b>33</b>	90	3		404054
	<b>34</b>	855	2		287131
	<b>35</b>	4815	69 (55)	Dach Bretter Madrier de toit Roof board	284526
	<b>36</b>	3630	38(31)	Boden Bretter Plancher bois Floor board	283514
	<b>37</b>	2390	25(20)		...
	<b>38</b>	1190	25(20)		...

Alle maßen ca +/-3% / les dimensions des pièces peuvent évoluer +/- 3% / size tolerance +/- 3%

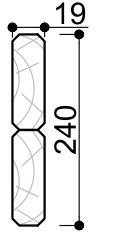
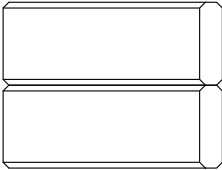
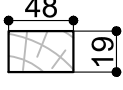
→||←40mm

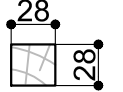
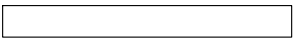
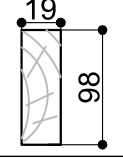
SPECIFICATION 5,8 x 3,9

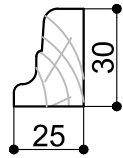
**40212**

		38a	4860	1+1	Wind Brett Planche de rive Wind board	285050
		38b				285051
		39a	3019	1+1		285059
		39b				285060
		40	2400	4	Wind Brett Planche de rive Wind board	286516
		41	3019	2		286521
		42	2140	1	Wind Brett Planche de rive Wind board	286045
		43	1680	2		286046
		44	3000	2	Wind Brett Planche de rive Wind board	286038
		45	3400	1		283285
		46	2170	3		283291
		47	2850	1		283295
		48	1200	1		283292
		49	2400	1		283293
		50	1400	3		283294
		51	2400	1		283293

Alle maßen ca +/-3% / les dimensions des pièces peuvent évoluer +/- 3% / size tolerance +/- 3%

→||←40mm

## SPECIFICATION

5,8 x 3,9

40212

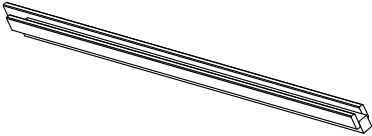
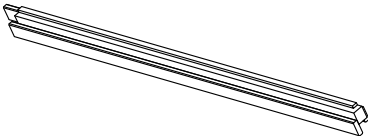
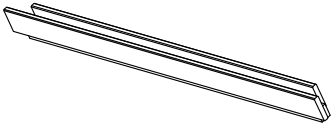
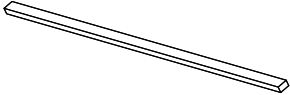
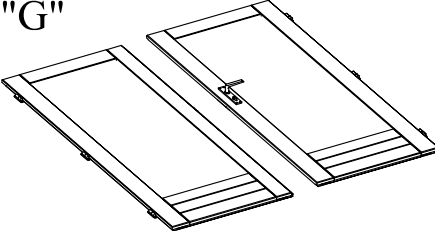
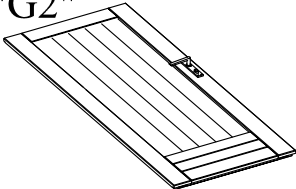
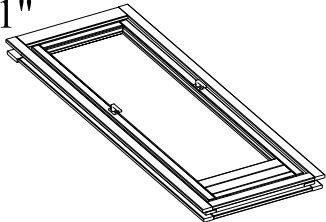
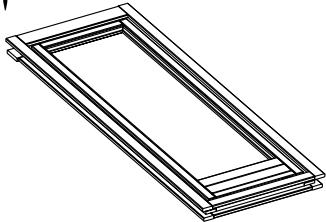
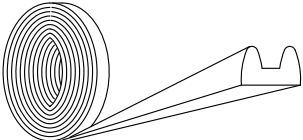
	(TR1)	1973	1	Türrahmen links Cadre de porte gauche Door frame left	409224
	(TR5)	1973	2		409228
	(TR2)	1973	1	Türrahmen rechts Cadre de porte droite Door frame right	409225
	(TR6)	1973	2		409225
	(TR3)	1700	1	Über Türrahmen Montant supérieur Door frame top	409226
	(TR7)	945	2		409229
	(TR4)	1500	1	Türstufe Latte de finition bas Door frame bottom	409227
	(TR8)	745	2		409230
"G" 	(T1)	1850x 765	1	Tür Porte Doors	289020 T1
	(T2)	1850x 765	1		289020 T2
"G2" 	(T3)	1850x 765	1	Tür Porte Doors	289023
	(T3)	1850x 765	1		289023
"G1" 	(F1)	1955x 700	2	Fenster Fenêtre Window	409111
"G" 	(F2)	1955x 700	1	Fenster Fenêtre Window	409112
		27m	1	Dichtgummi étanchéité en caoutchouc sealing rubber	

→||←40mm

SPECIFICATION 5,8 x 3,9

**40212**

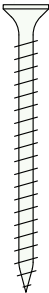
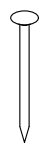
	Pos.	Dim	Stck.
		Ø4.5 x 100	12
		Ø3.5 x 60	82
		Ø3.2 x 39	140
		Ø5.0 x 120	24
		Ø2.0 x 40	630
		Ø2.0 x 50	550

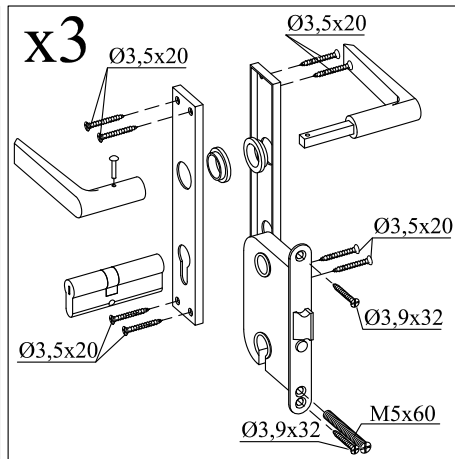

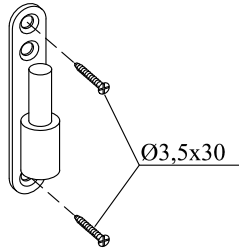
Skizze	Stck.
	12

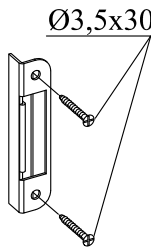
Skizze	Stck.
	2

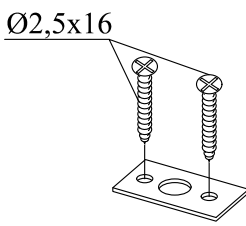
Skizze	Stck.
	2

Skizze	Stck.
	2

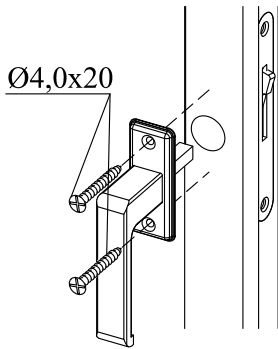
Skizze	Stck.
	4

→||←40mm

5,8 x 3,9

**40212**

**1**

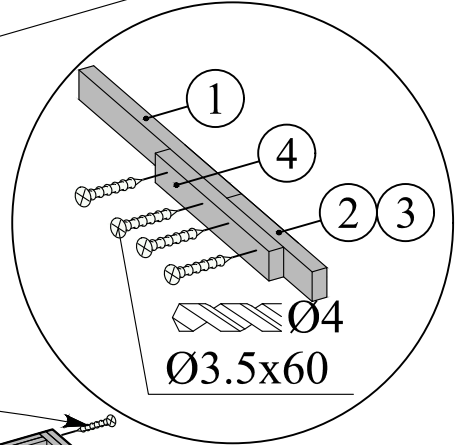
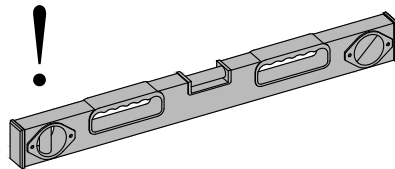
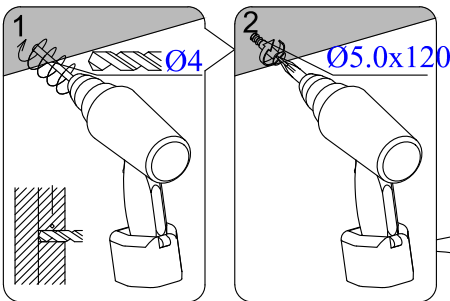
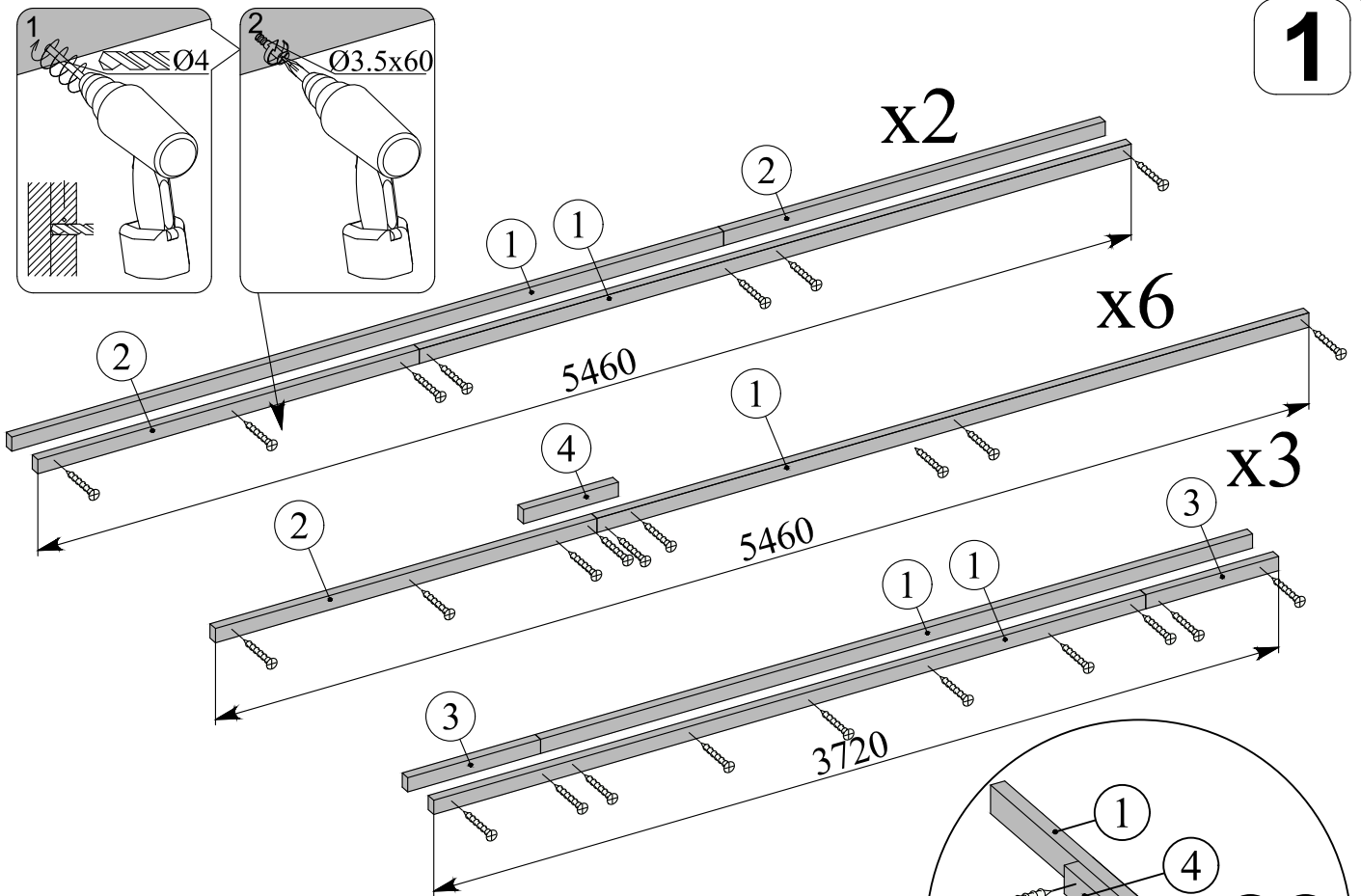

**2**

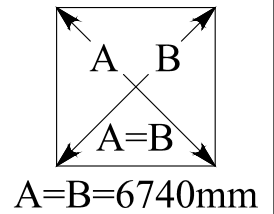
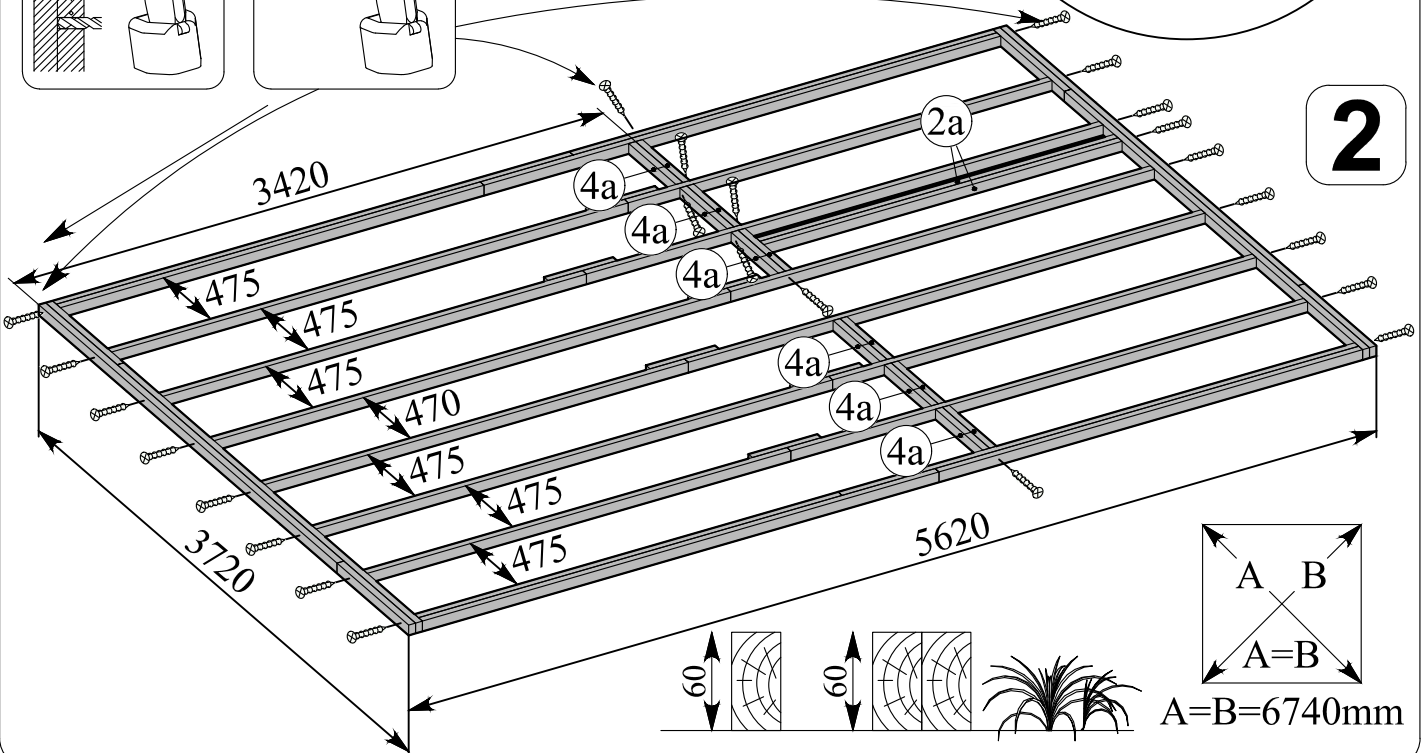

→||←40mm

5,8 x 3,9

40212

3

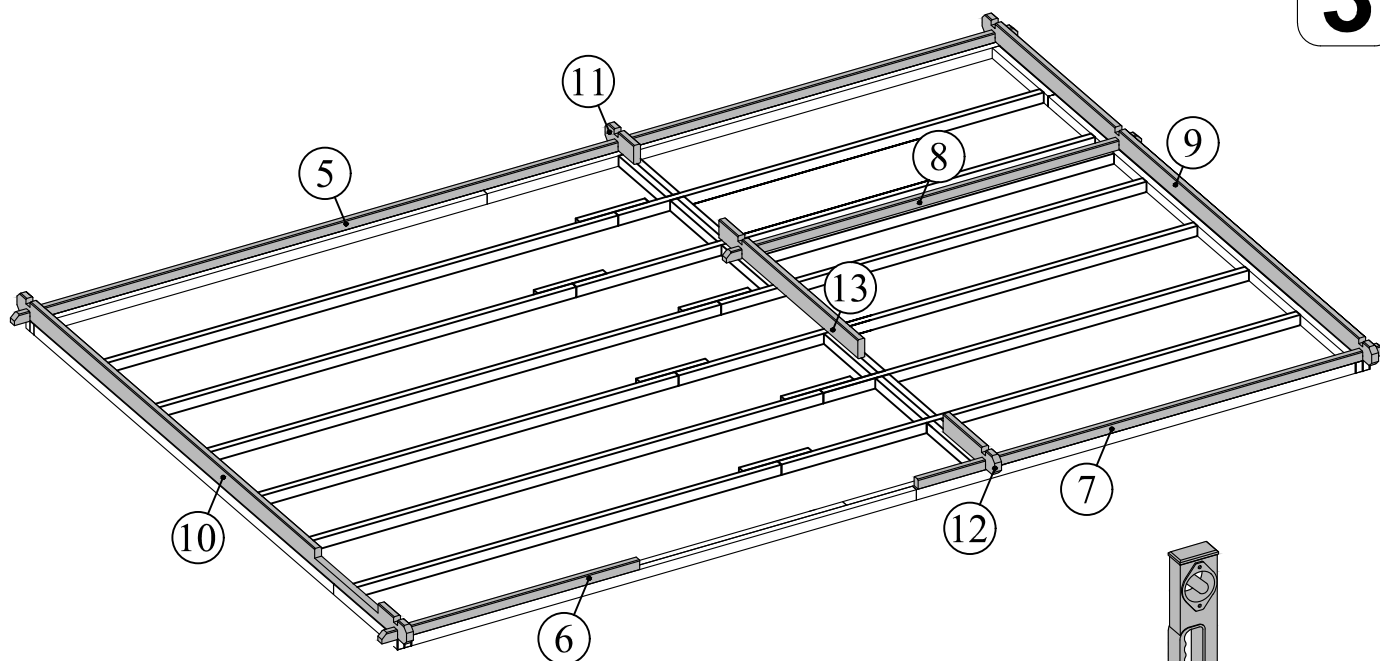

4

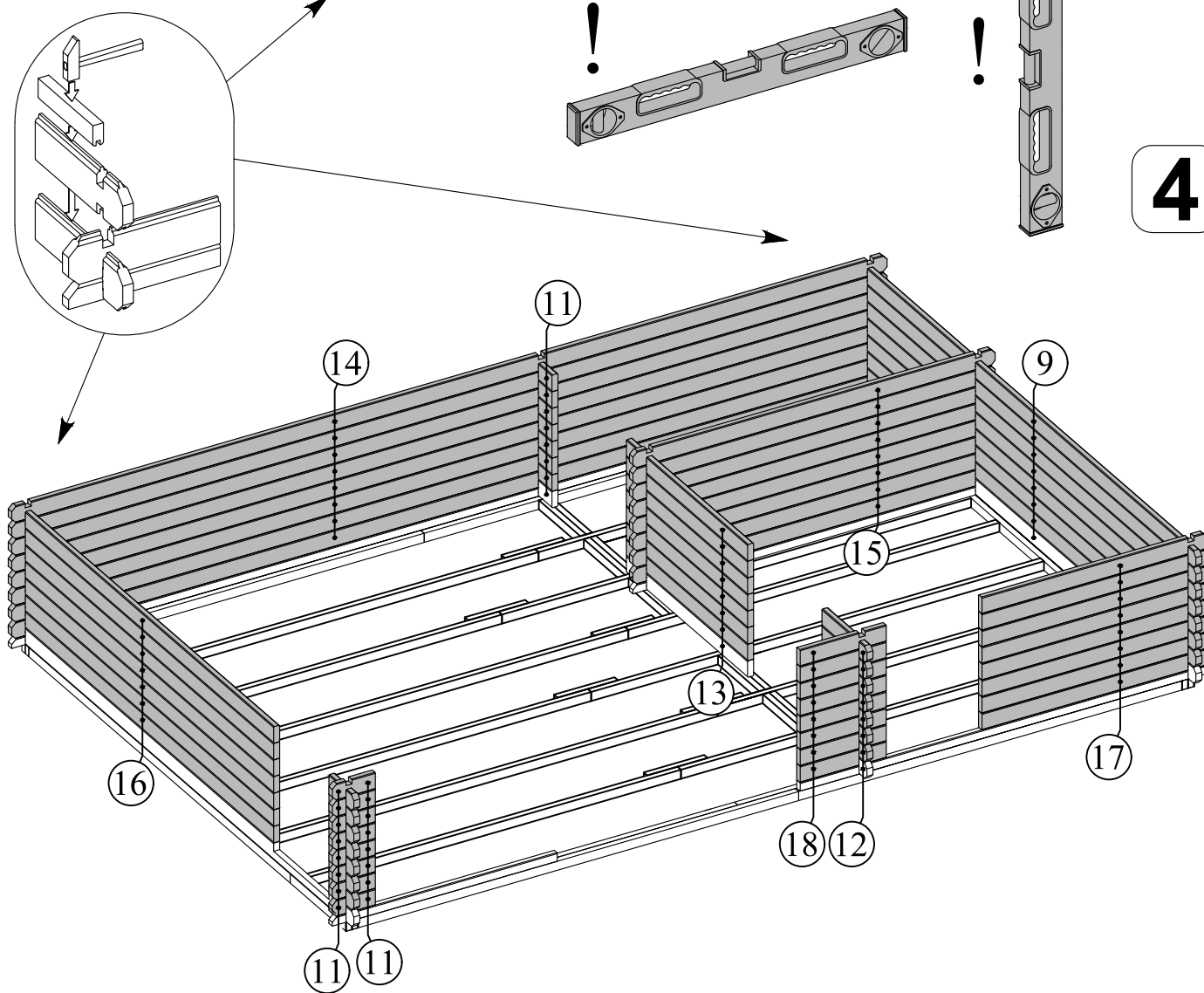

→||←40mm

5,8 x 3,9

40212

5

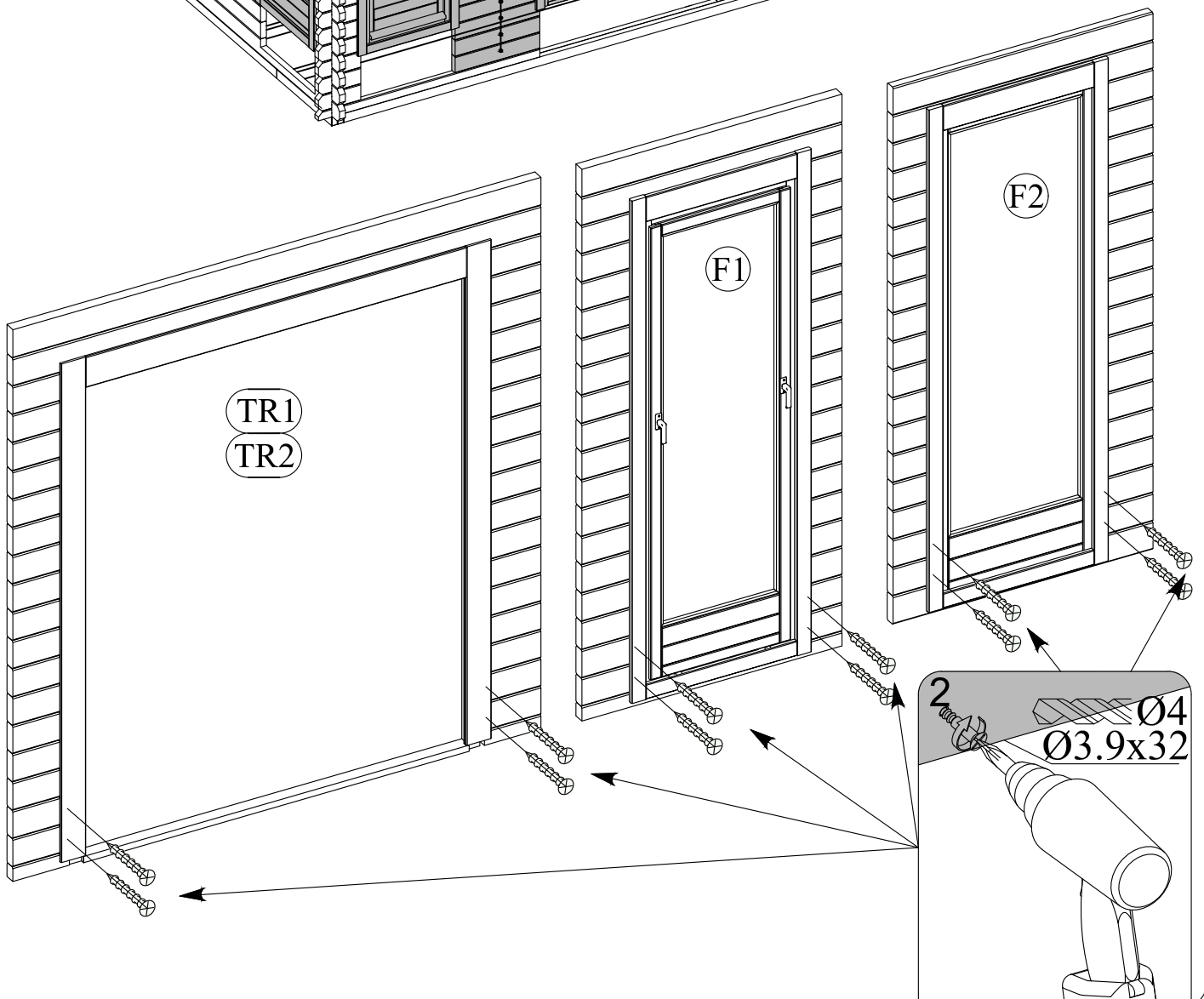
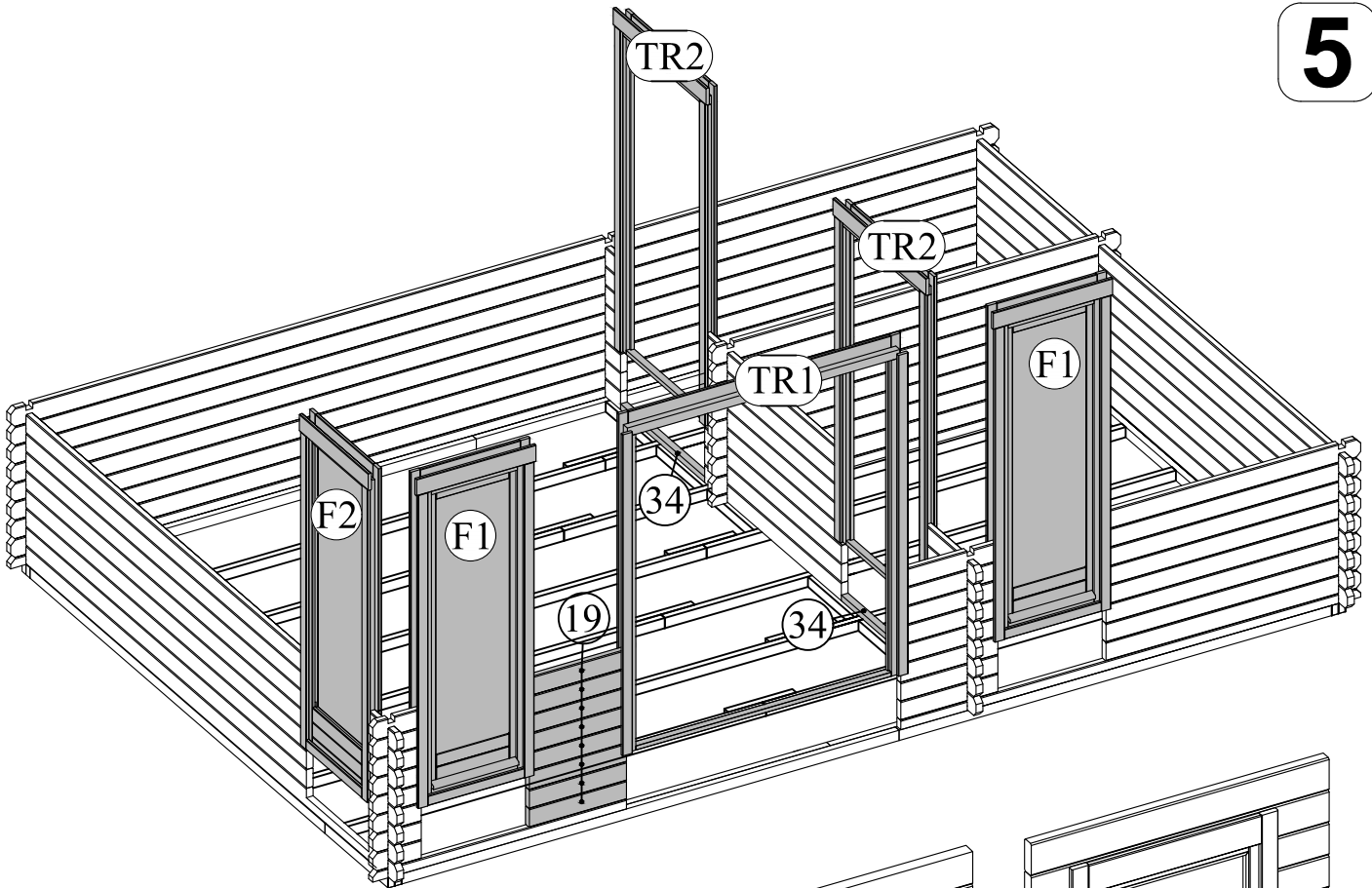

→||←40mm

5,8 x 3,9

**40212**

**6**

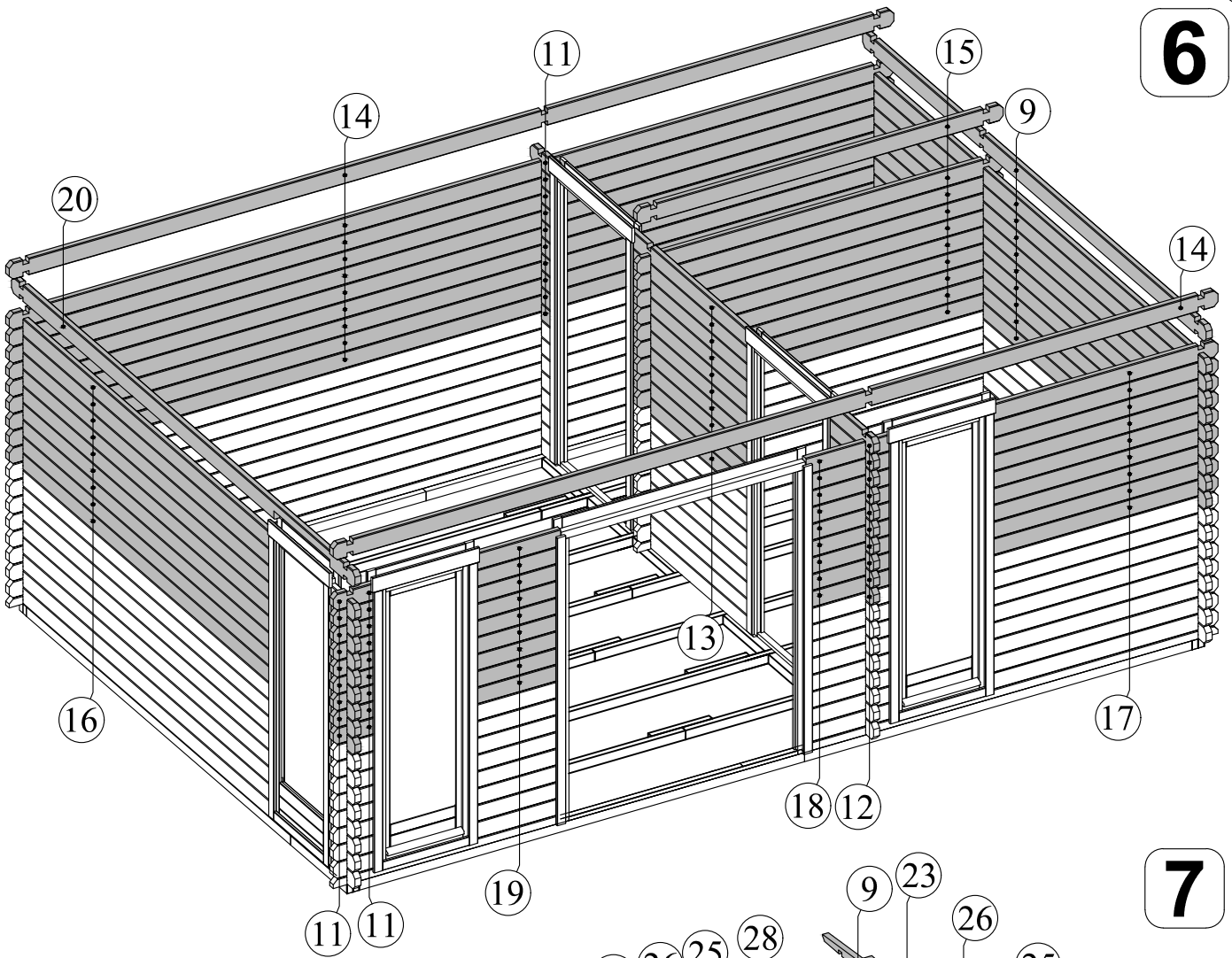

**7**

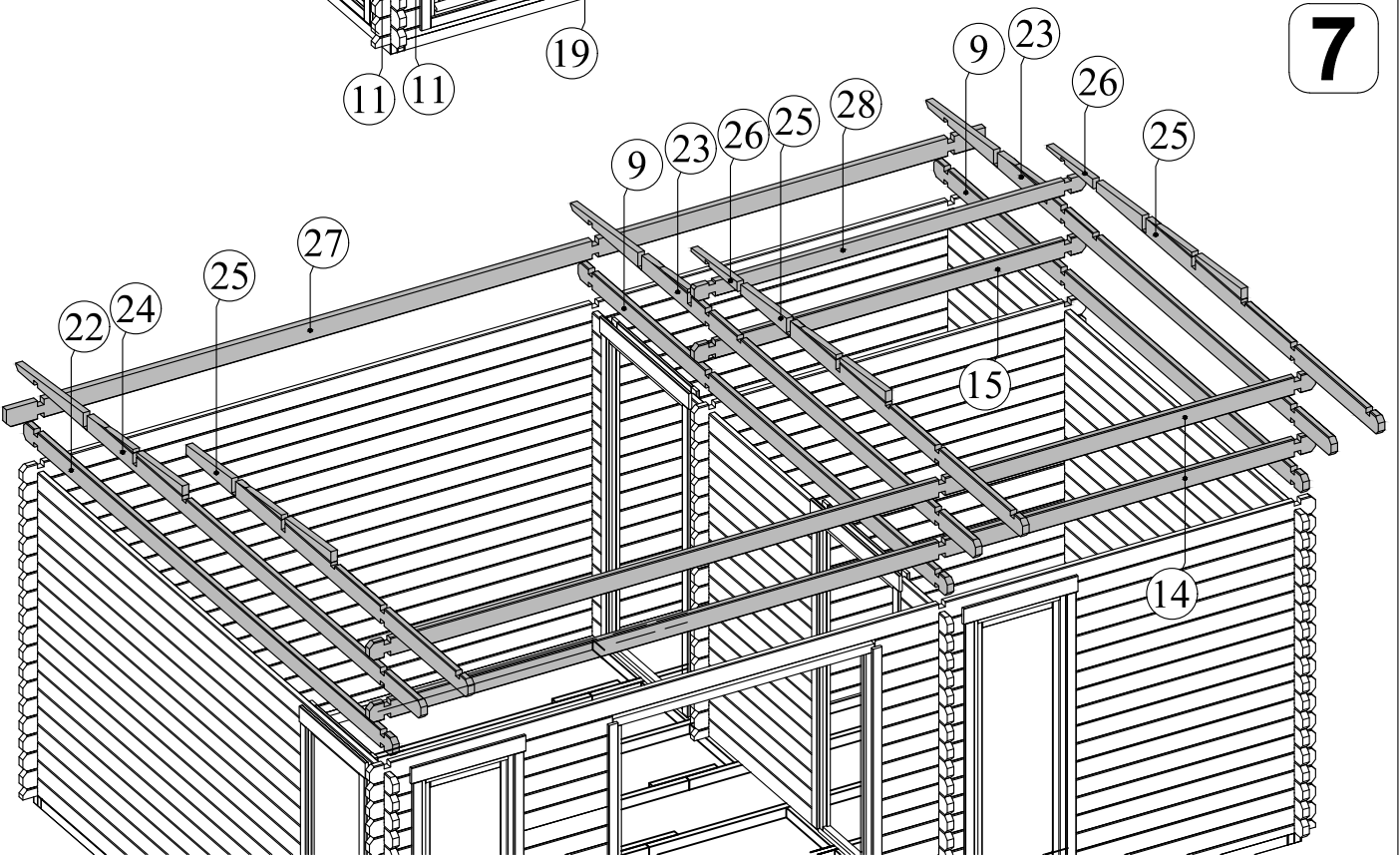

→||←40mm

5,8 x 3,9

40212

8

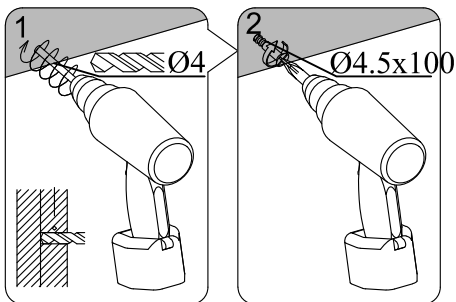
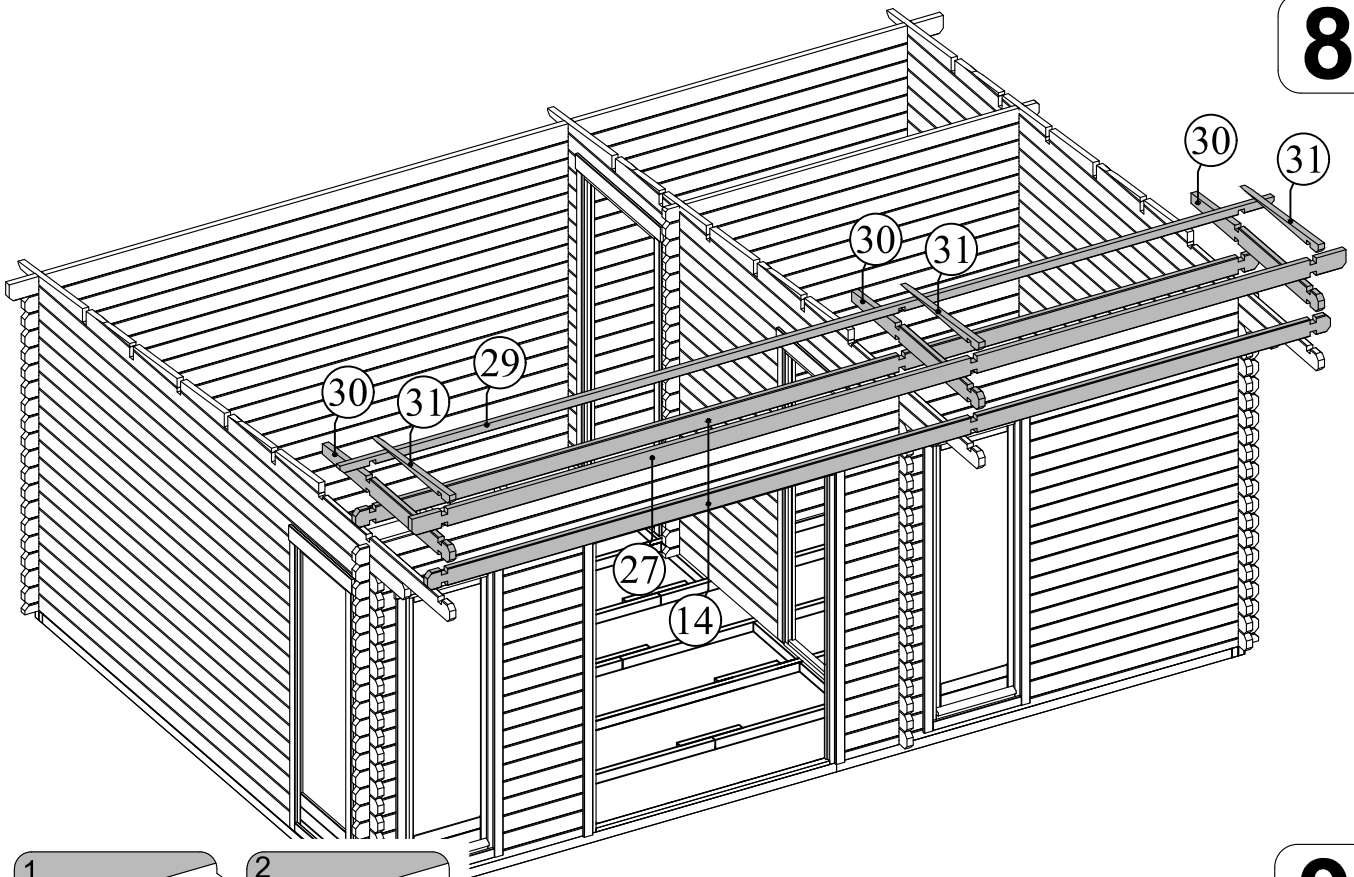

9

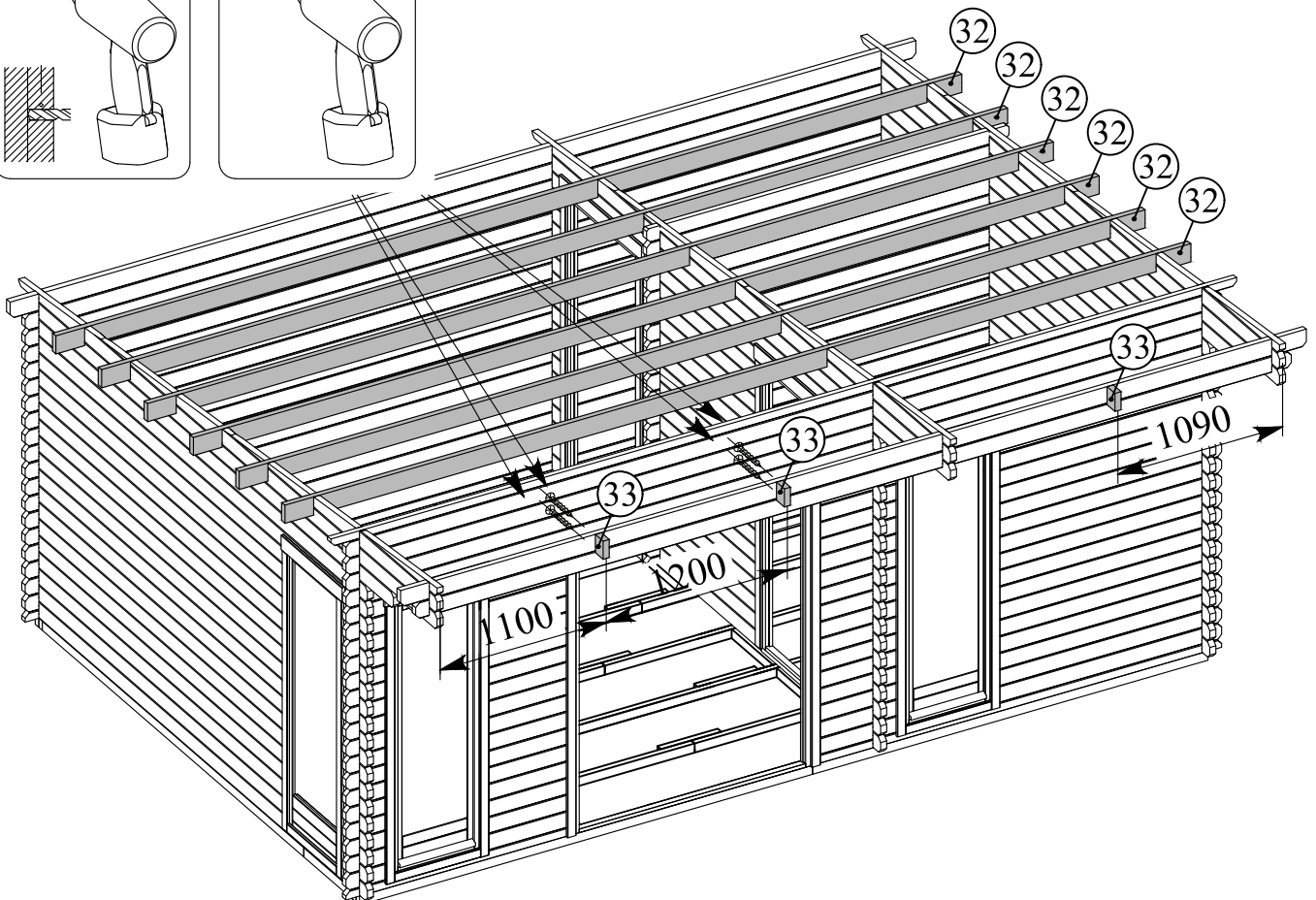

→||←40mm

5,8 x 3,9 **40212**

**10**

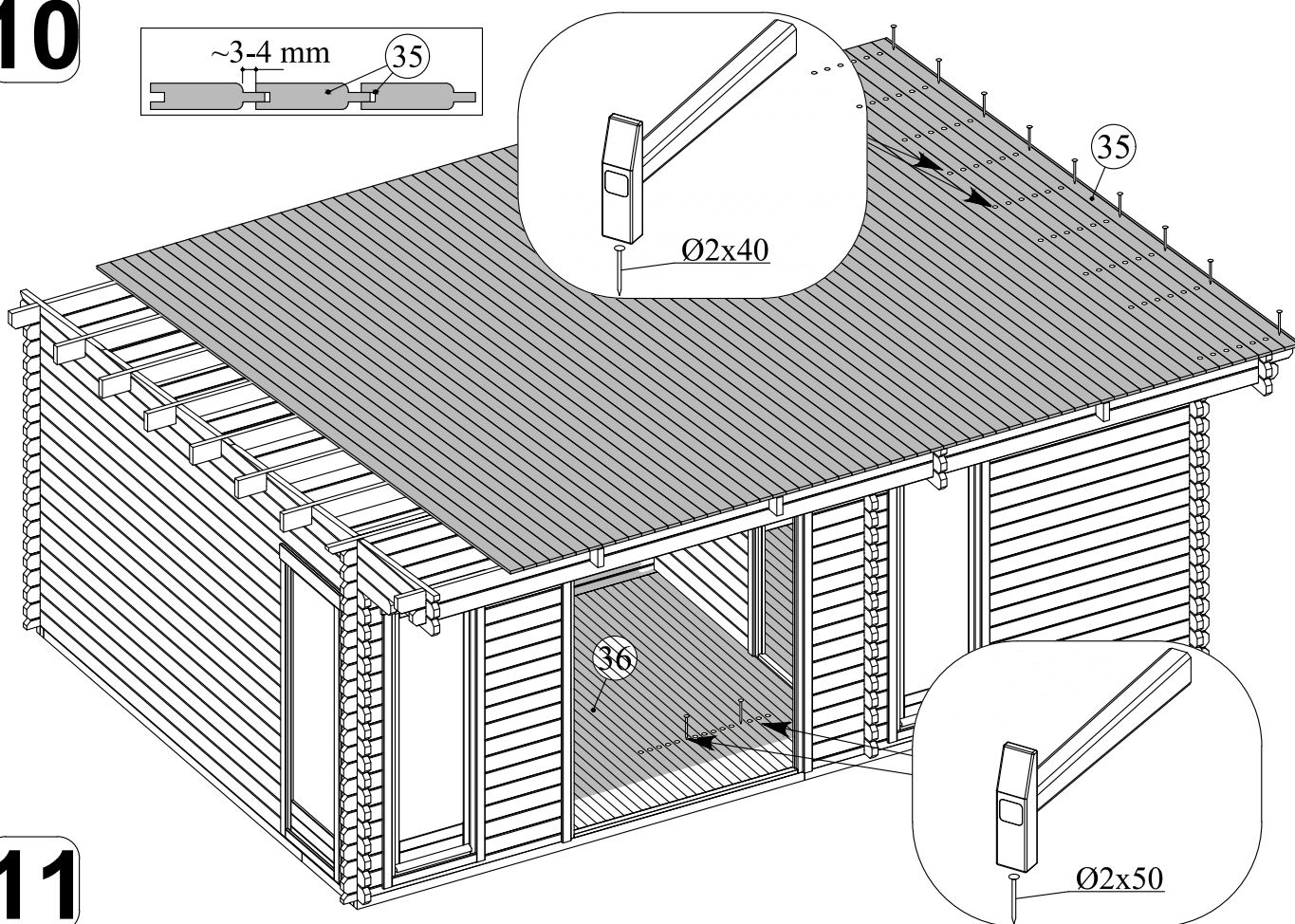

**11**

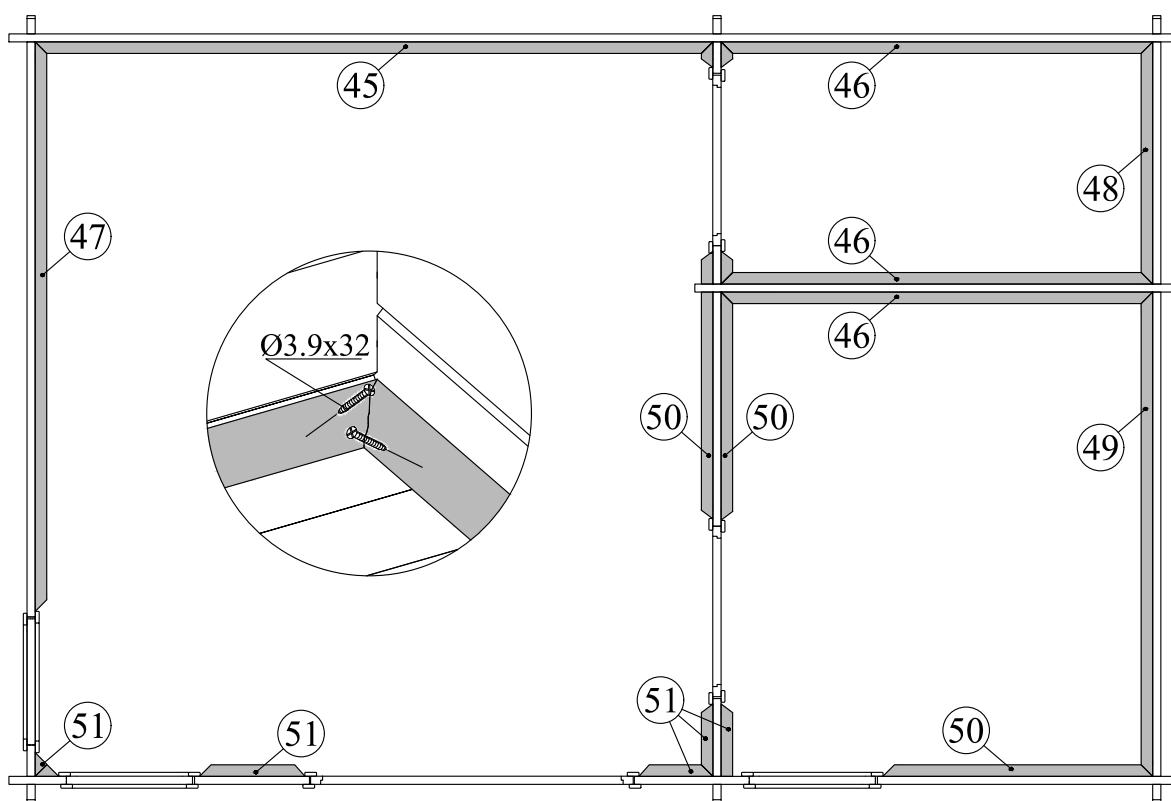

→||←40mm

5,8 x 3,9

40212

12

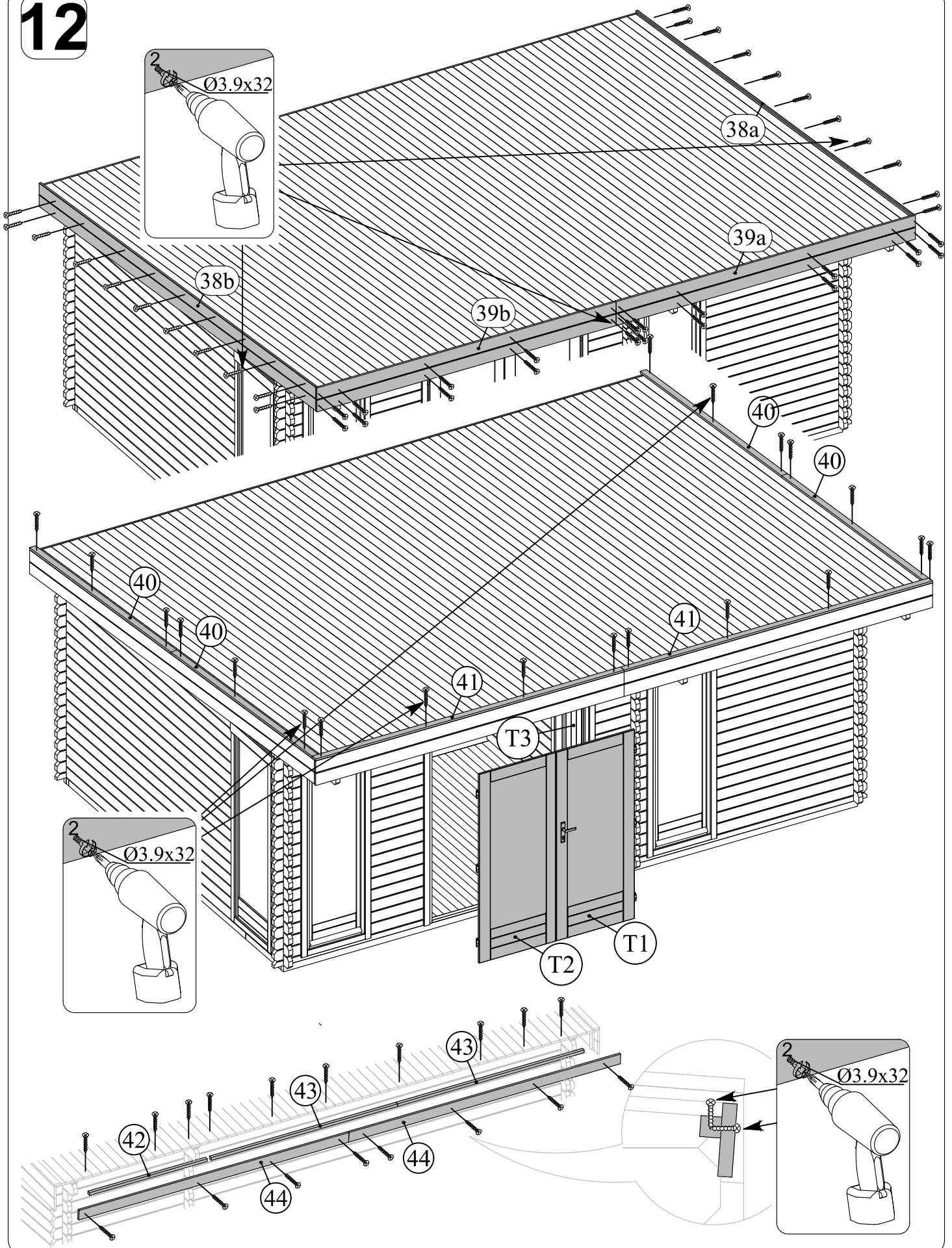

→ || ← 40mm

5,8 x 3,9

40212

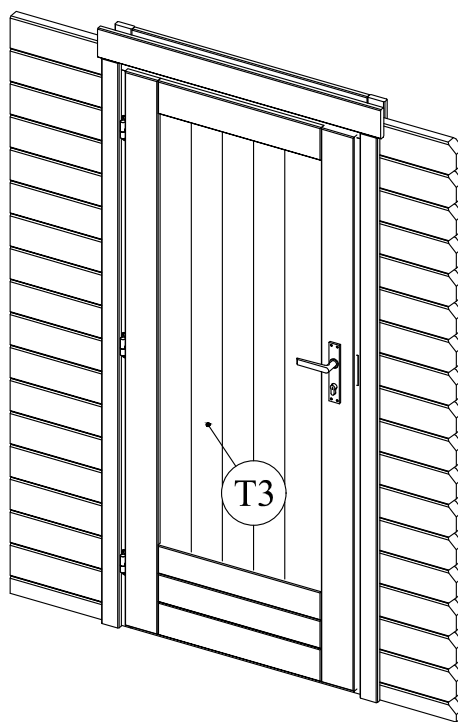
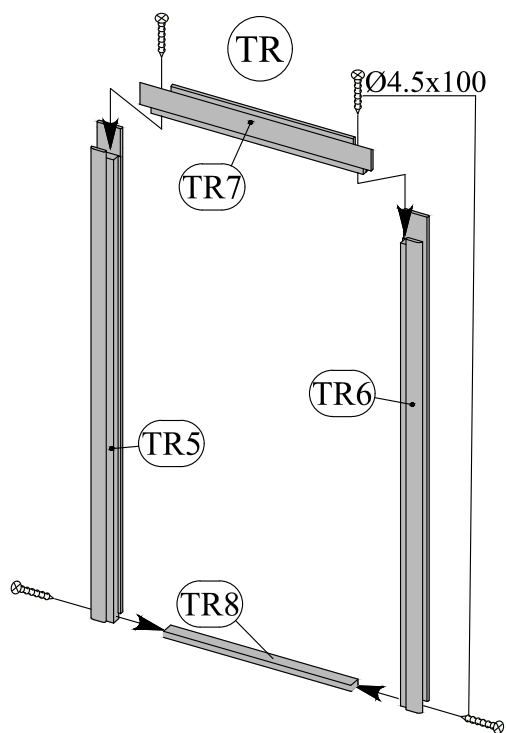
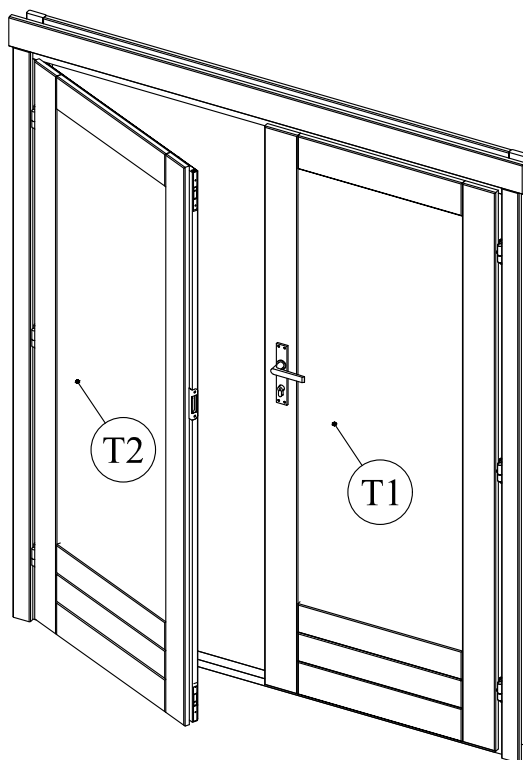
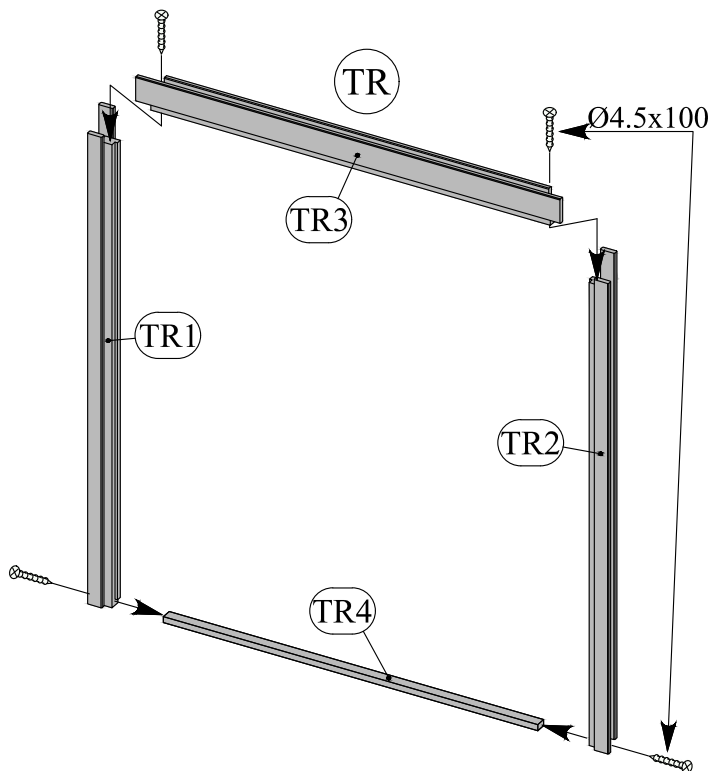

→||←28mm

3.6 x 3.0 **40212**

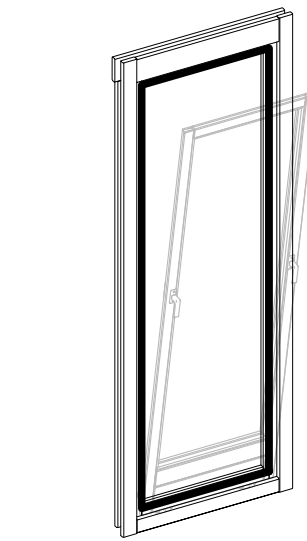
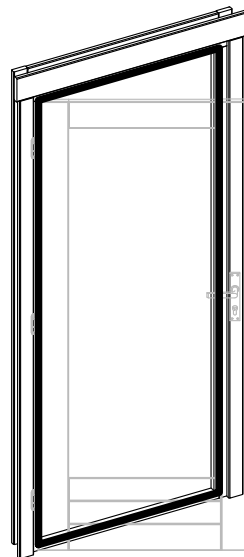
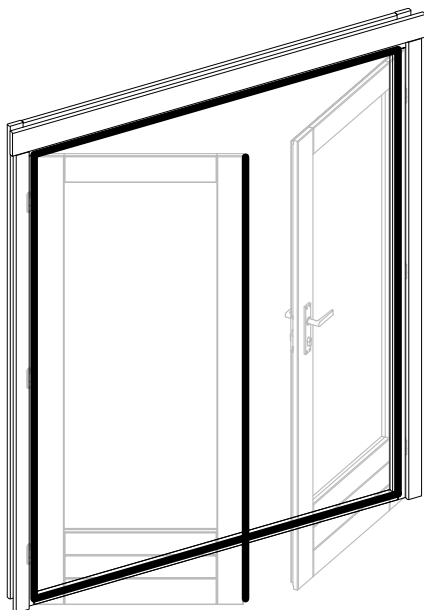
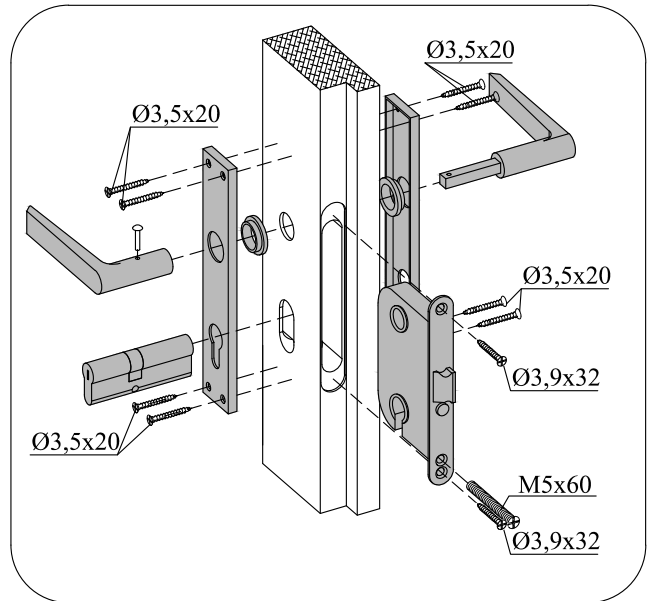
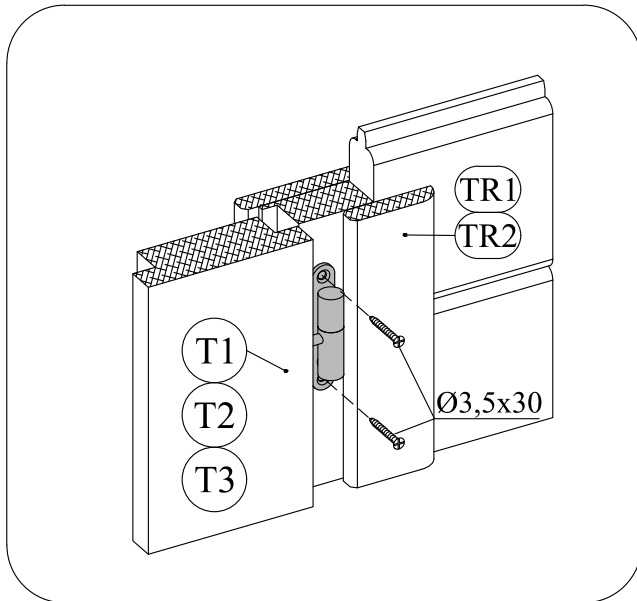
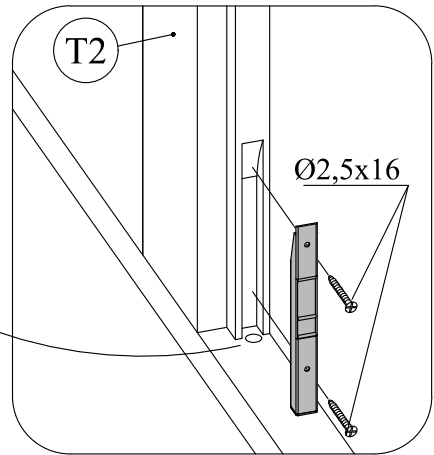
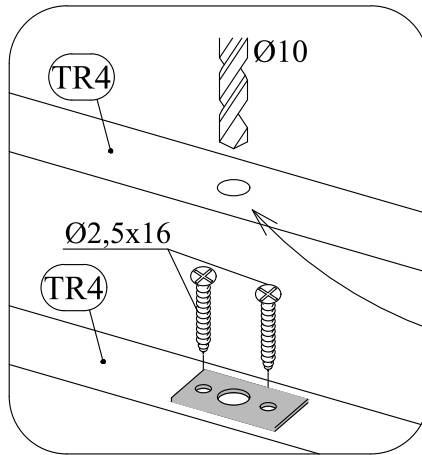
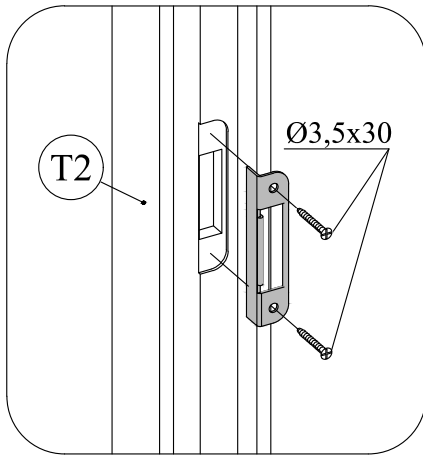

Dichtgummi  
étanchéité en caoutchouc  
sealing rubber

