

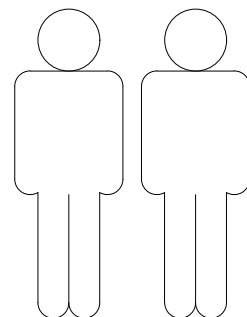

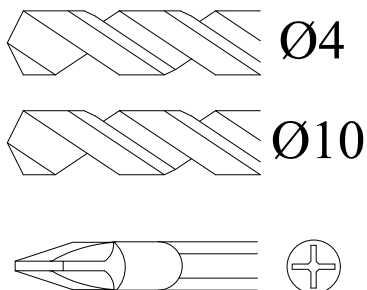

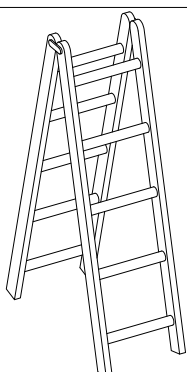

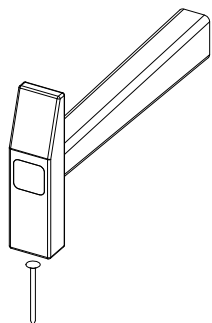

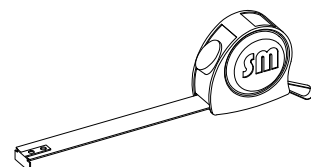
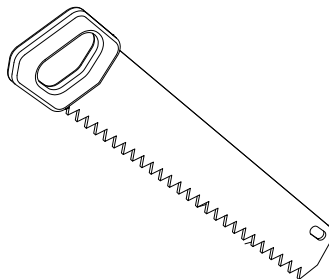
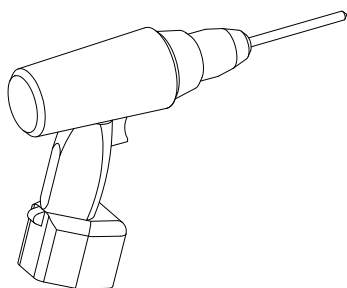
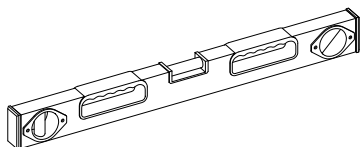
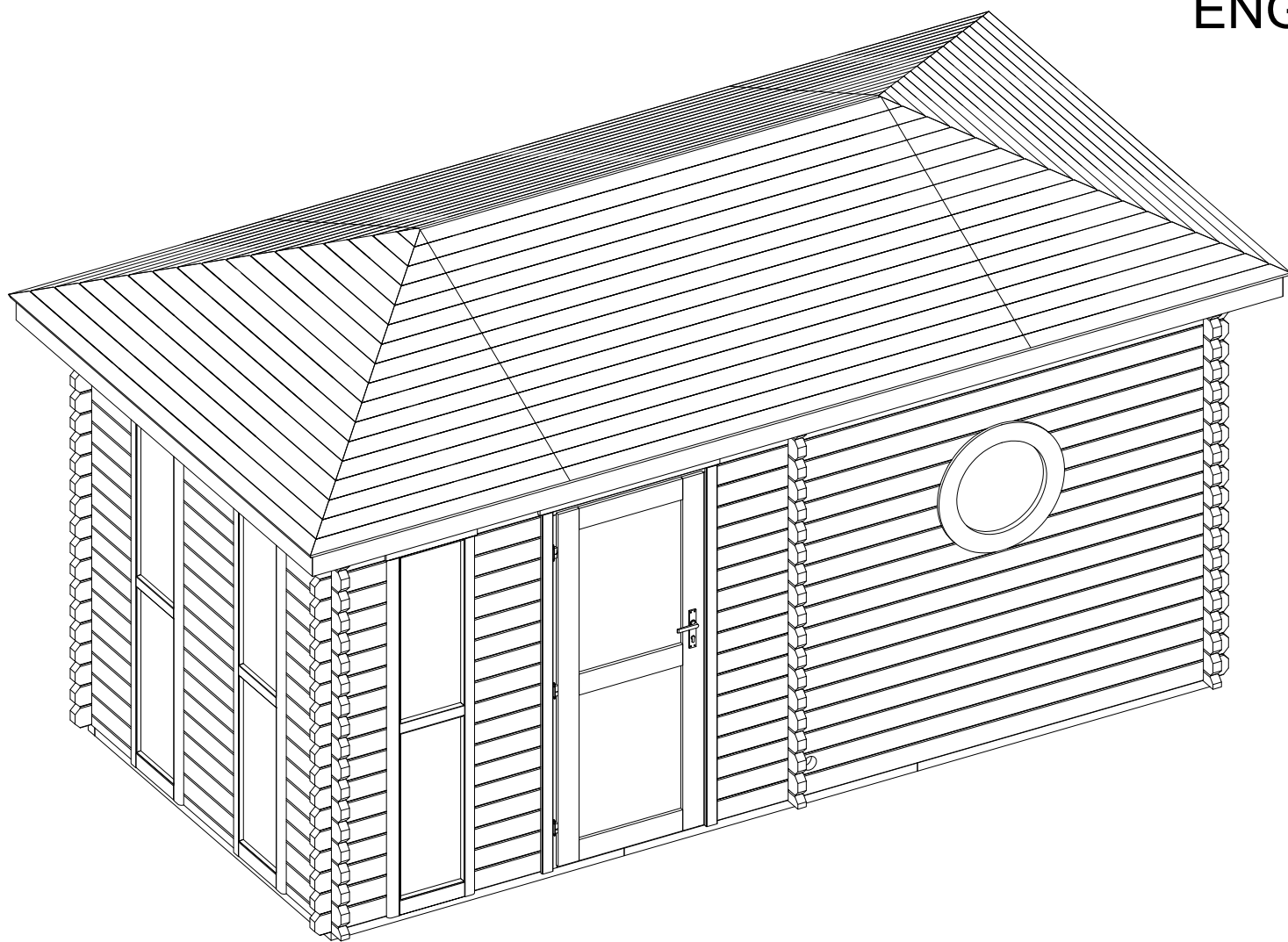
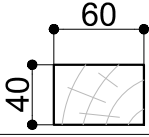



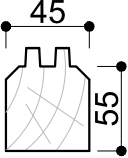
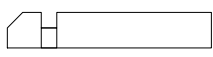
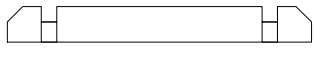
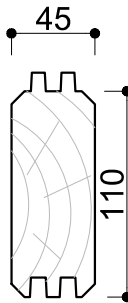
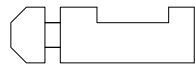

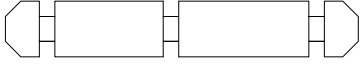

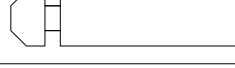
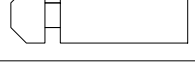

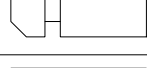
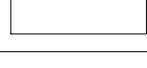
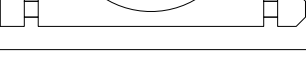
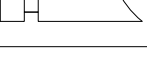

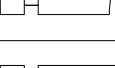
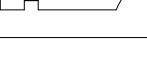
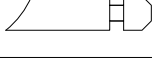
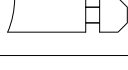

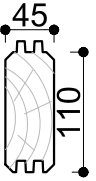

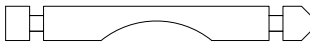
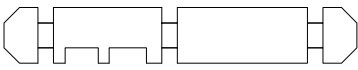
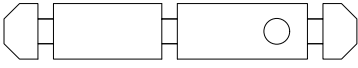

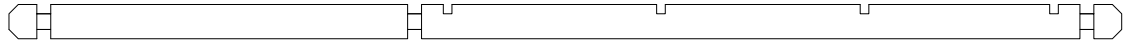
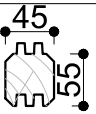

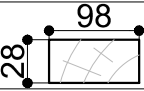

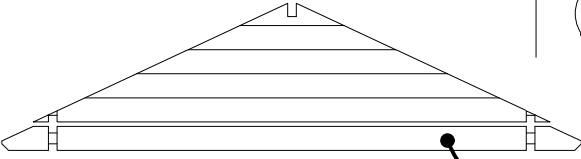

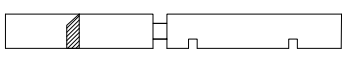
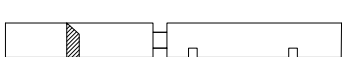

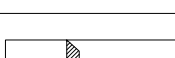
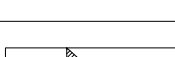
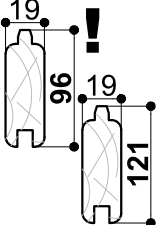

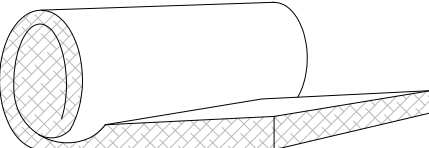

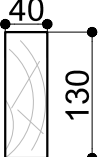
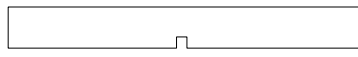
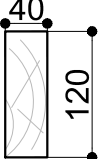

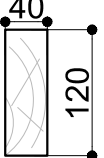
DE  
ENG

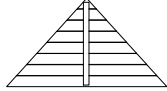
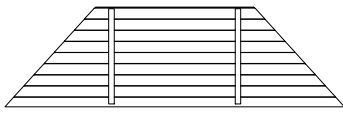
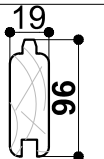
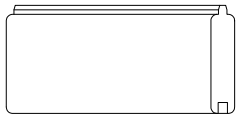
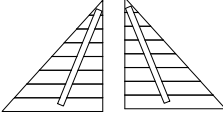
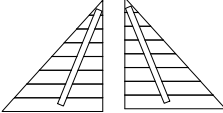
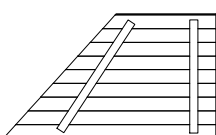
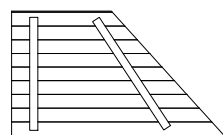
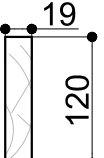

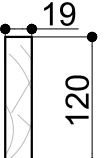
Dim.	Skizze/Sketch	Pos.	Länge/length (mm)	Stck. /Total	Name	Ref.
		①	2090	10	Fundamentbalken Foundation beam	283062
		②	1540	6		283070
		③	400	4		283084
		④	772	2	Mitte Brett Middle board	450001
		⑤	2400	2	Seiten Brett Side board	450004
		⑥	1222	1	Front Brett Front board	450027
		⑦	2721	10	Front Brett Front board	450028
		⑧	4800	19+1	Front, Zurück Brett Front, back board	450024
		⑨	2721	1	Front Brett Front board	450029
		⑩	2400	22+1	Seiten Brett Side board	450003
		⑪	772	34	Mitte Brett Middle board	450002
		⑫	533	34	Seiten Brett Side board	450021
		⑬	533	17	Seiten Brett Side board	450022
		⑭	411	16	Front Brett Front board	450036
		⑮	411	16	Front Brett Front board	450037
		⑯	2721	1	Front Brett Front board	450030
		⑰	1391	1	Front Brett Front board	450031
		⑱	1241	1	Front Brett Front board	450032
		⑲	1241	1	Front Brett Front board	450033
		⑳	1391	1	Front Brett Front board	450034
		㉑	1070	1	Front Brett Front board	450006
	㉒	920	1	Front Brett Front board	450007	
	㉓	920	1	Front Brett Front board	450008	

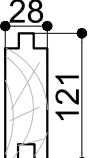
Alle maßen ca +/-3% / les dimensions des pièces peuvent évoluer +/- 3% / size tolerance +/- 3%

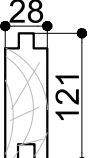
Dim.	Skizze/Sketch	Pos.	Länge/length (mm)	Stck. /Total	Name	Ref.
		24	1070	1	Front Brett Front board	450009
		25	2721	1	Front Brett Front board	450035
		26	4800	1	Front Brett Front board	450038
		27	4800	1	Zurück Brett Back board	450026
		28	2400	1	Mitte Brett Middle board	450012
		29	4800	2	Front, Zurück Brett Front, back board	450042
		31	2400	2	Seiten Brett Side board	450043
		32	2400	4	Sparren Beam	454004
	33	2400	1	Mitte panel Middle panel	452007	
		30	2645	1	Seiten Brett Side board	450044
		34a	2350	1	Seiten Brett Side board	451007
		34b	2350	1	Seiten Brett Side board	451010
		35a	1070	1	Seiten Brett Side board	451008
		35b	1070	1	Seiten Brett Side board	451011
		36	1070	6	Seiten Brett Side board	451009
		37	2120	25 20	Dachholzer Roof board	284514
	38				Mineralwolle Mineral wool	

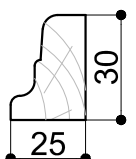
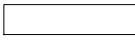
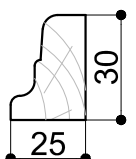
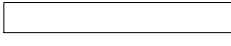
		39	2440	1	Sparren Rafters	454005
		40	1490	6	Sparren Rafters	454006
		41	1975	4	Sparren Rafters	454007
	42	1375	2	Dachplatte Roof panel	284620	
	43	2750	2	Dachplatte Roof panel	284621	
		44	2400	34	Dach Brett Roof boards	284633
	44a	650 x720	2+2	Dachplatte Roof panel	284631	
	44b				284632	
	45a	1375 x805	2+2	Dachplatte Roof panel	284636	
					45b	284637
		46	5080	2	Wind Brett Wind Board	285034
		47	2655	2	Wind Brett Wind Board	285035
		48	2120	20	Bodenholzer Floor board	283517
		49	2360	20	Bodenholzer Floor board	283524
		50	2135	10	Fussbodenleisten Baseboard	283241
		51	2360	2	Fussbodenleisten Baseboard	283261

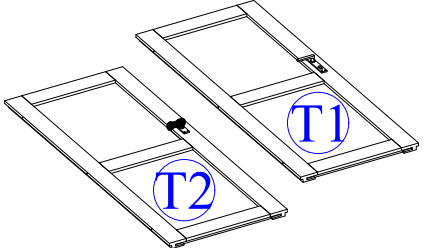
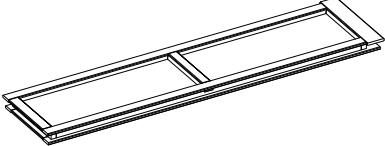
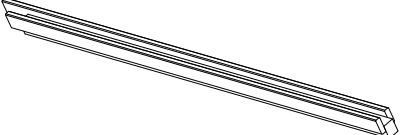
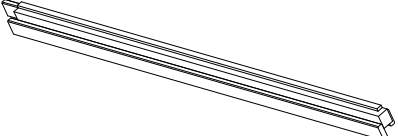
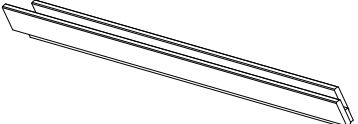
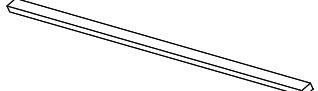
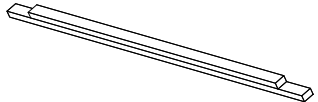
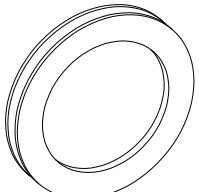
	T1	1850x 765	1	Tür Doors	289016
	T2	1850x 765	1		289017
	F	1870x 400	3	Fenster Window	459104
	TR1a	1973	1	Türrahmen links Door frame left	459201
	TR1b		1		459205
	TR2	1973	2	Türrahmen rechts Door frame right	459202
	TR3	945	2	Über Türrahmen Door frame top	459203
	TR4	745	1	Türstufe Door frame bottom	459204
	TR5	845	1	Türstufe Door frame bottom	459206
	F1	550x 550	1	Fenster Window	459101

Alle maßen ca +/-3% / les dimensions des pièces peuvent évoluer +/- 3% / size tolerance +/- 3%

1

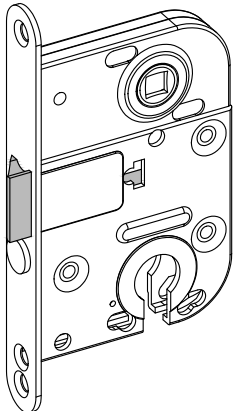

2

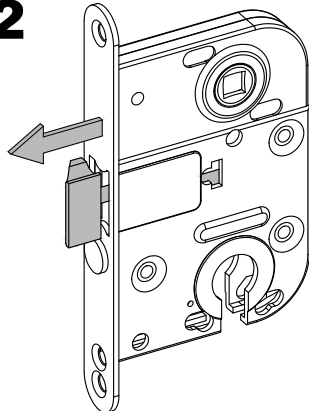

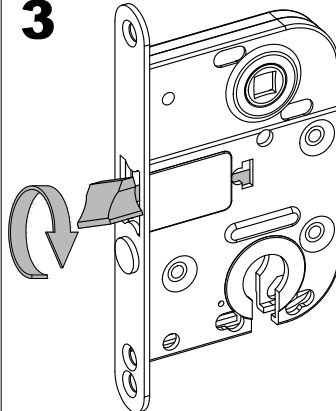

3

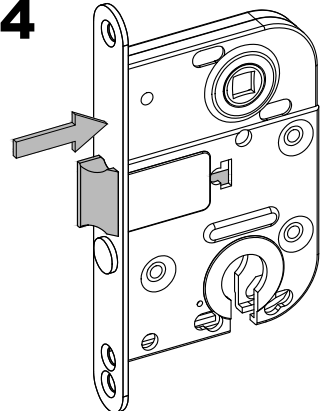

4

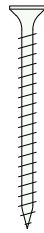

	Dim	Stck.
	Ø5.0 x 100	56
	Ø4.5 x 80	11
	Ø3.5 x 40	70
	Ø2.0 x 40	430
	Ø2.0 x 50	200

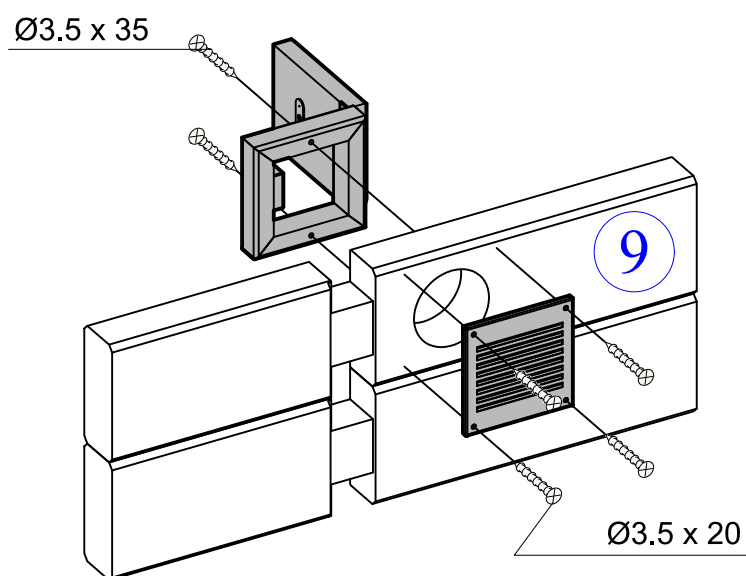
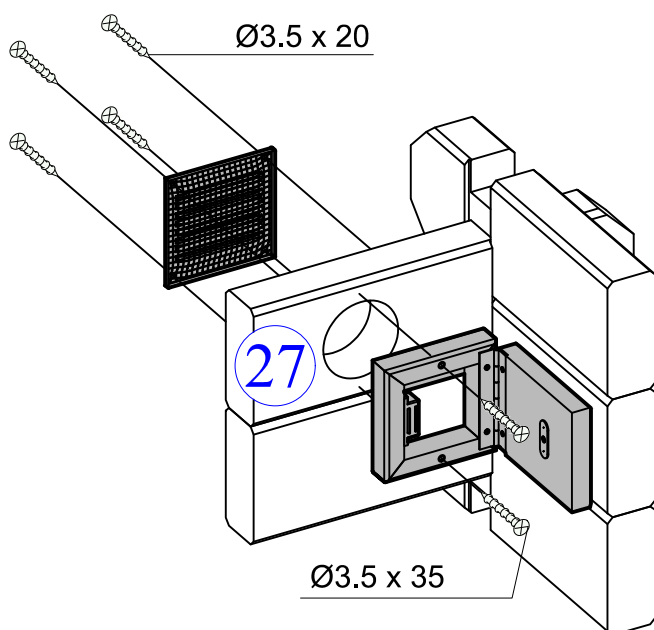
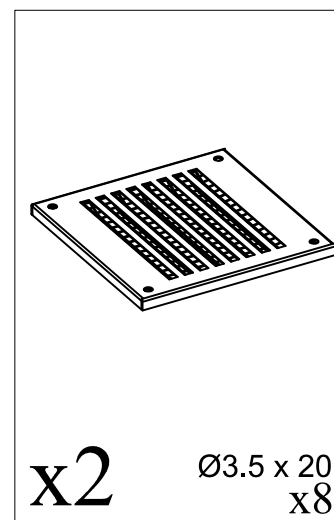
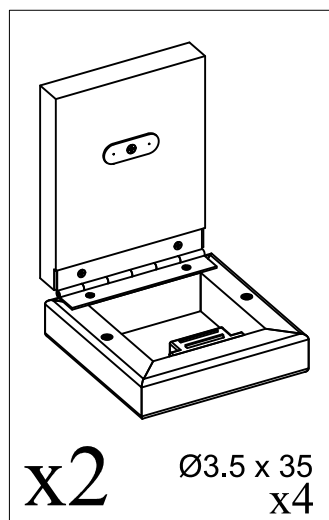
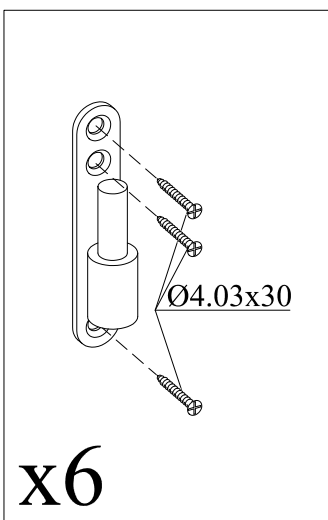
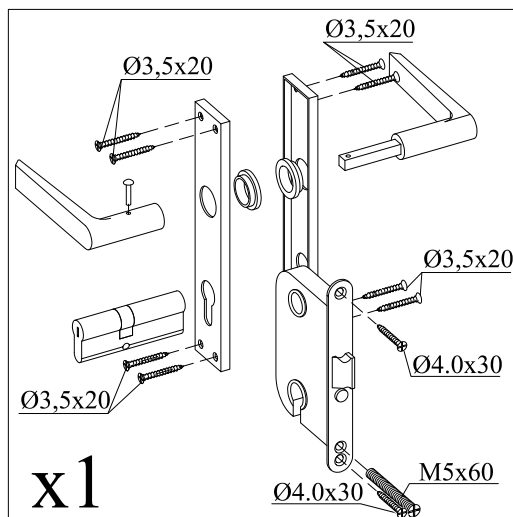
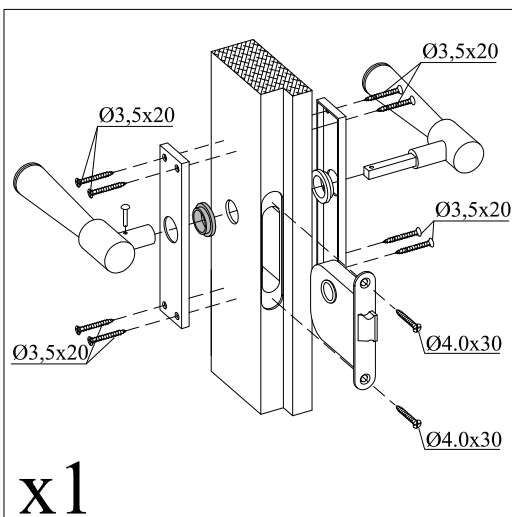

1

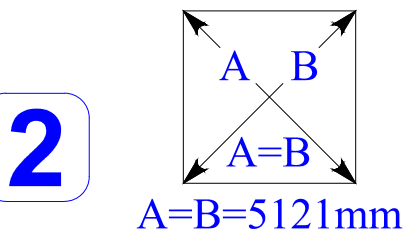
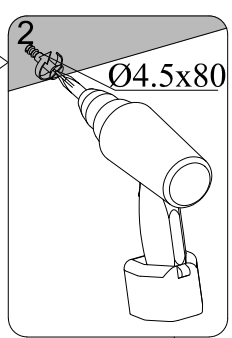
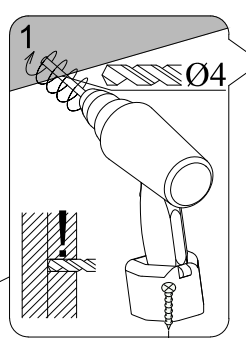
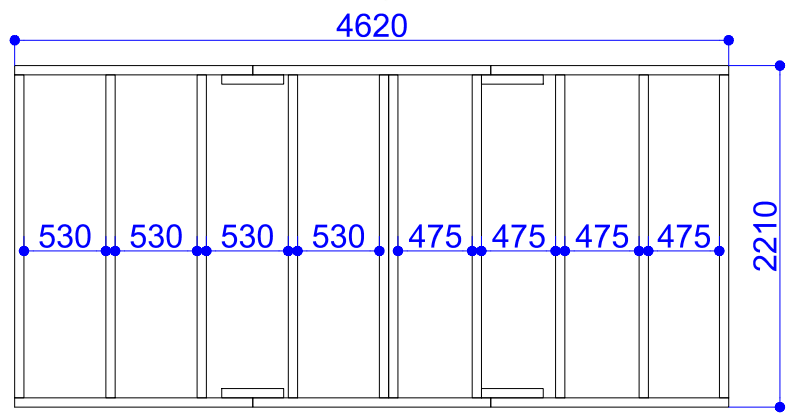
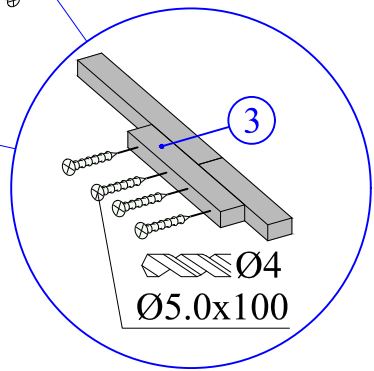
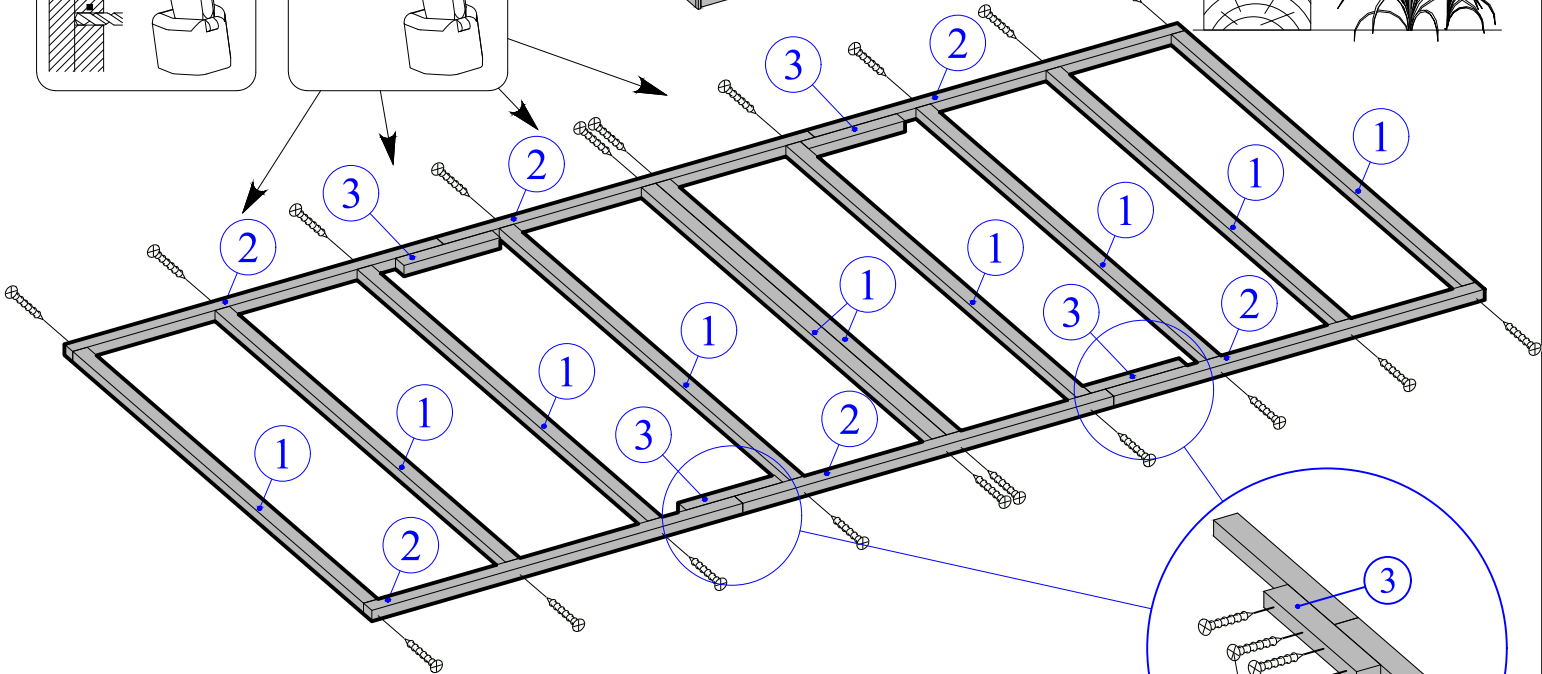
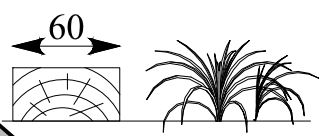
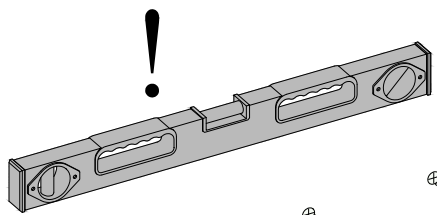
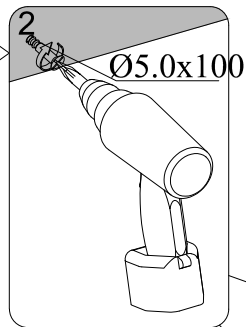
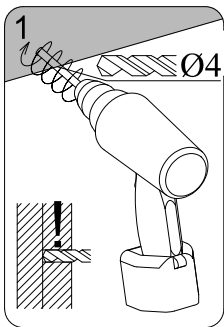

2

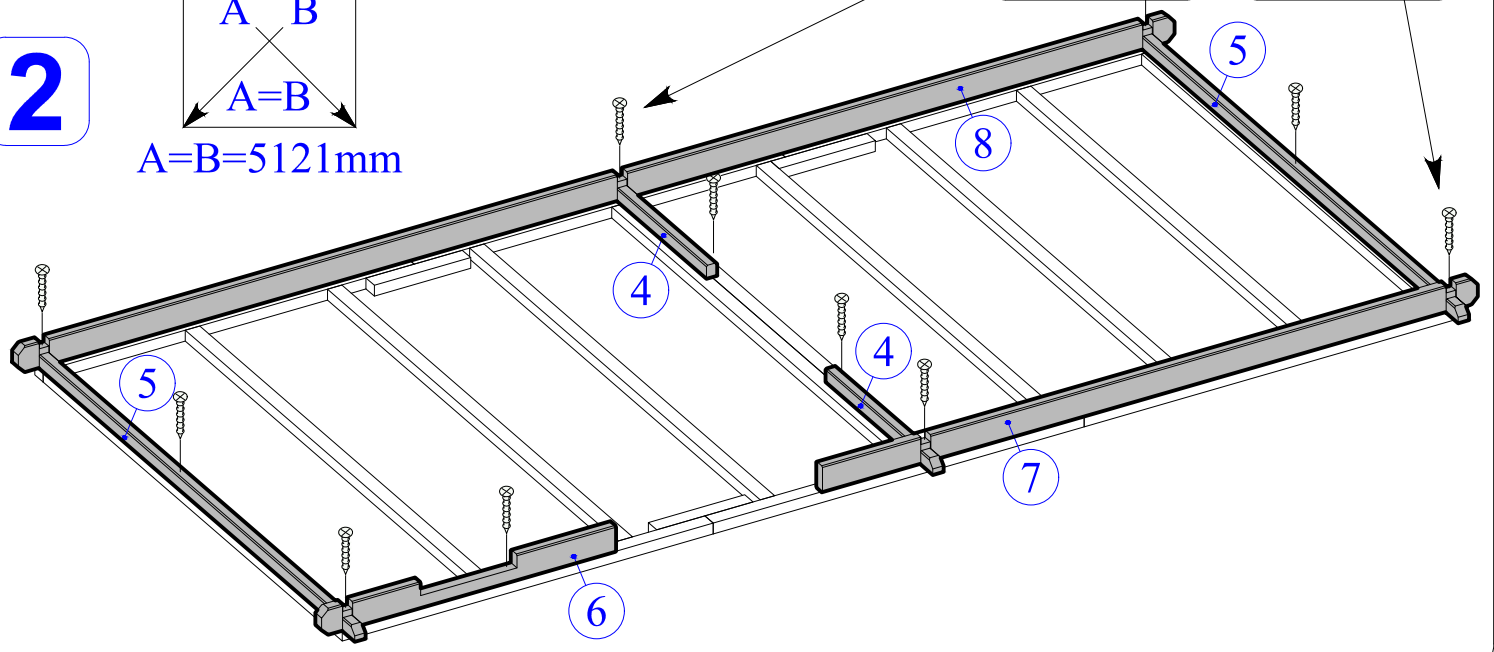

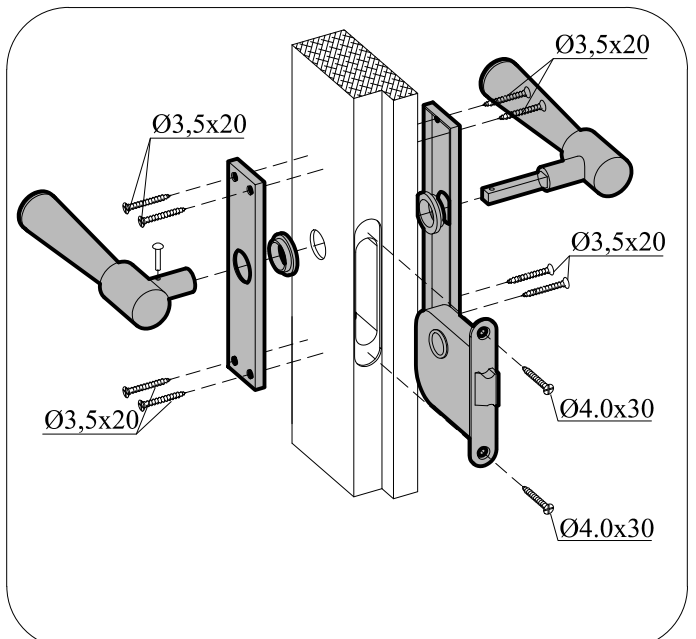
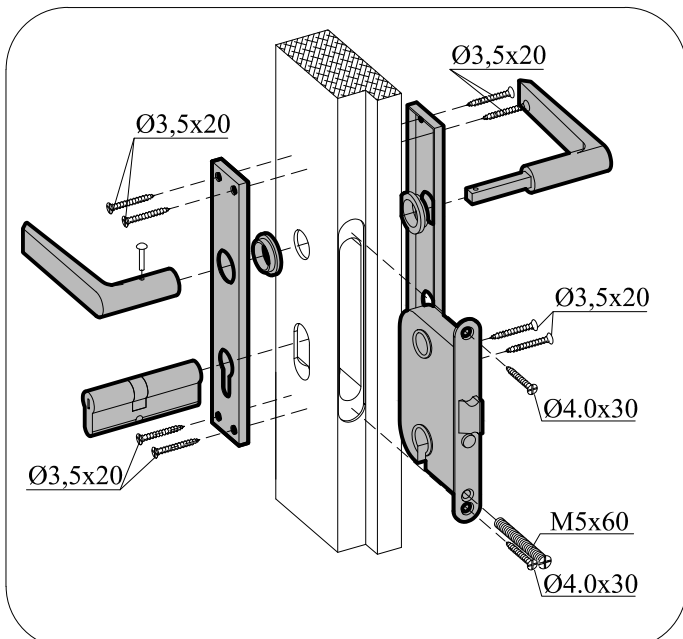
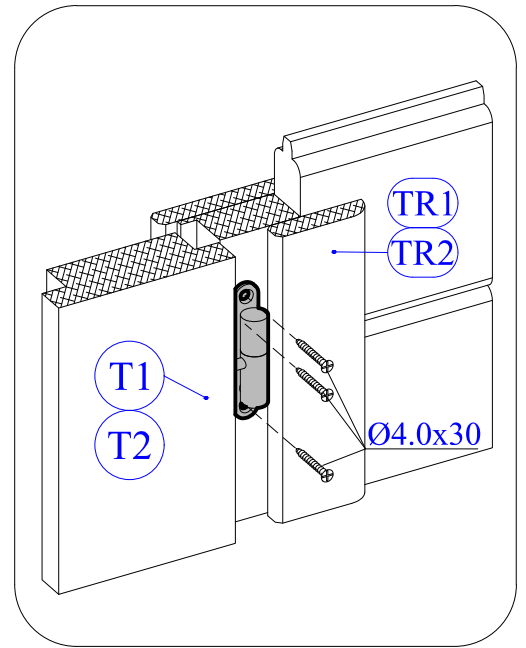
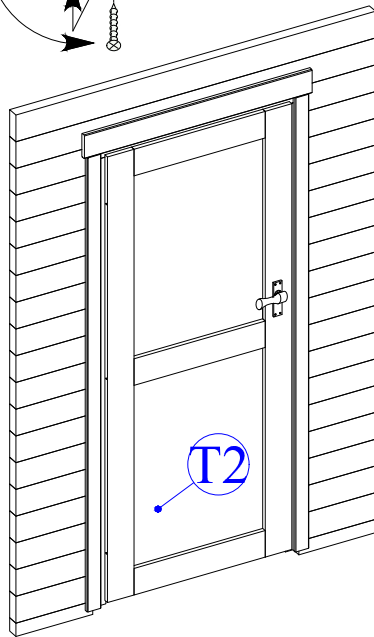
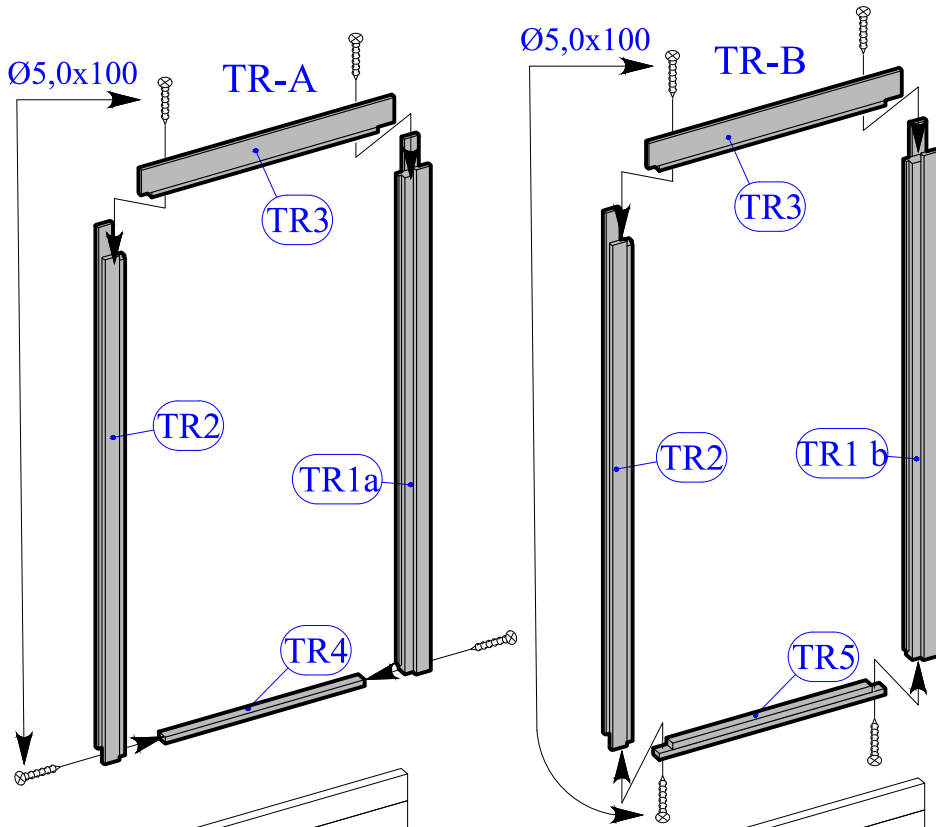

3

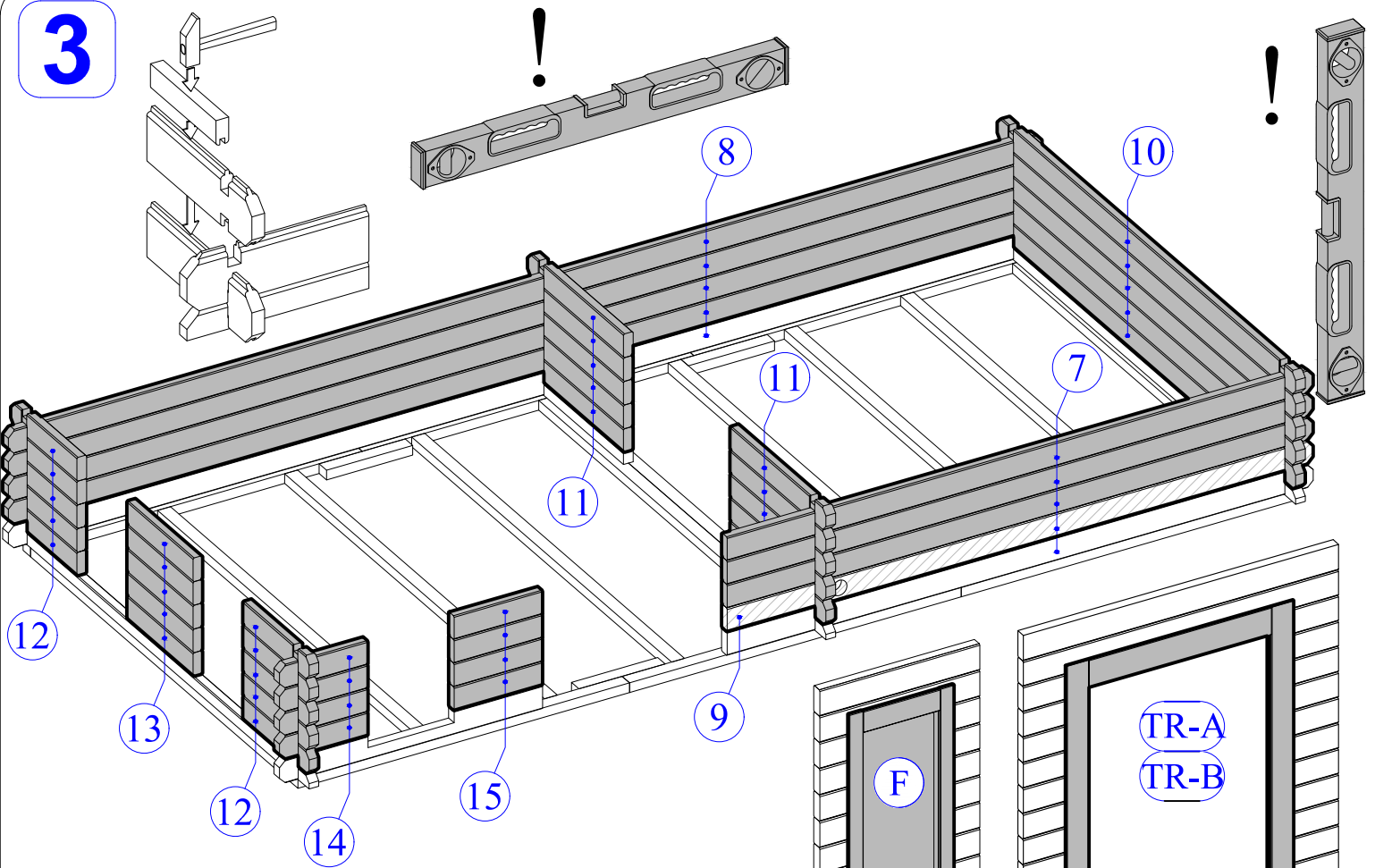

4

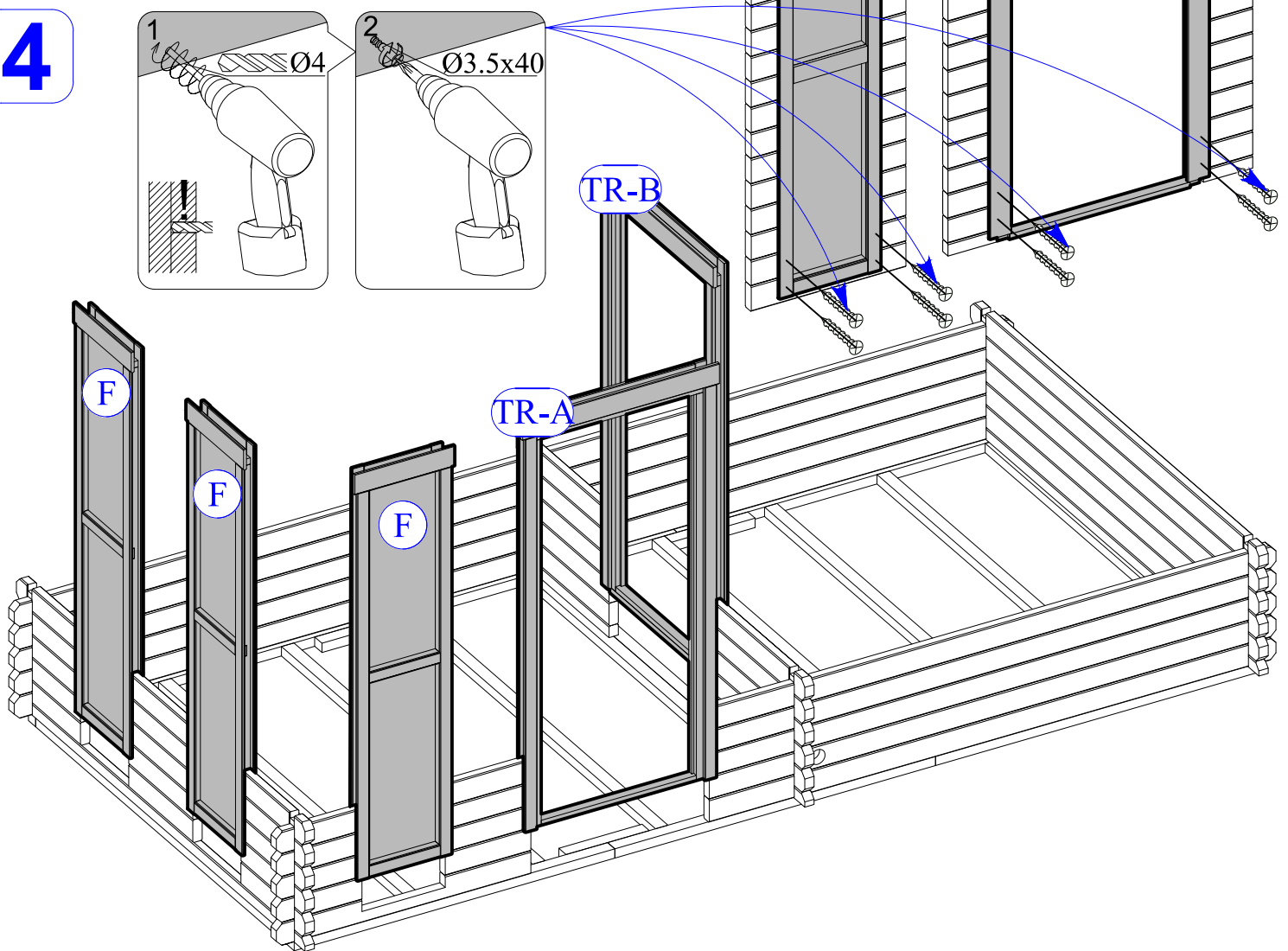

5

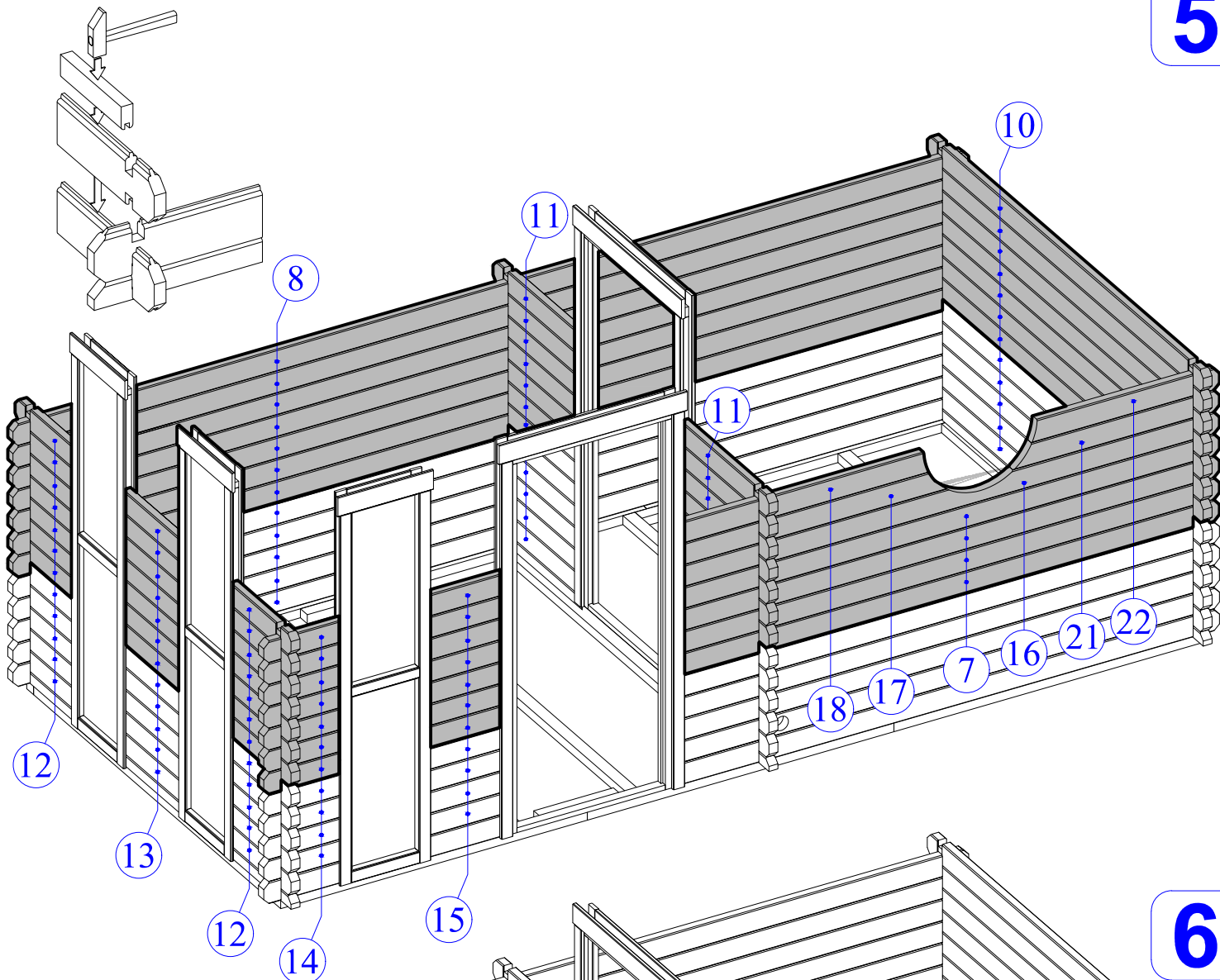

6

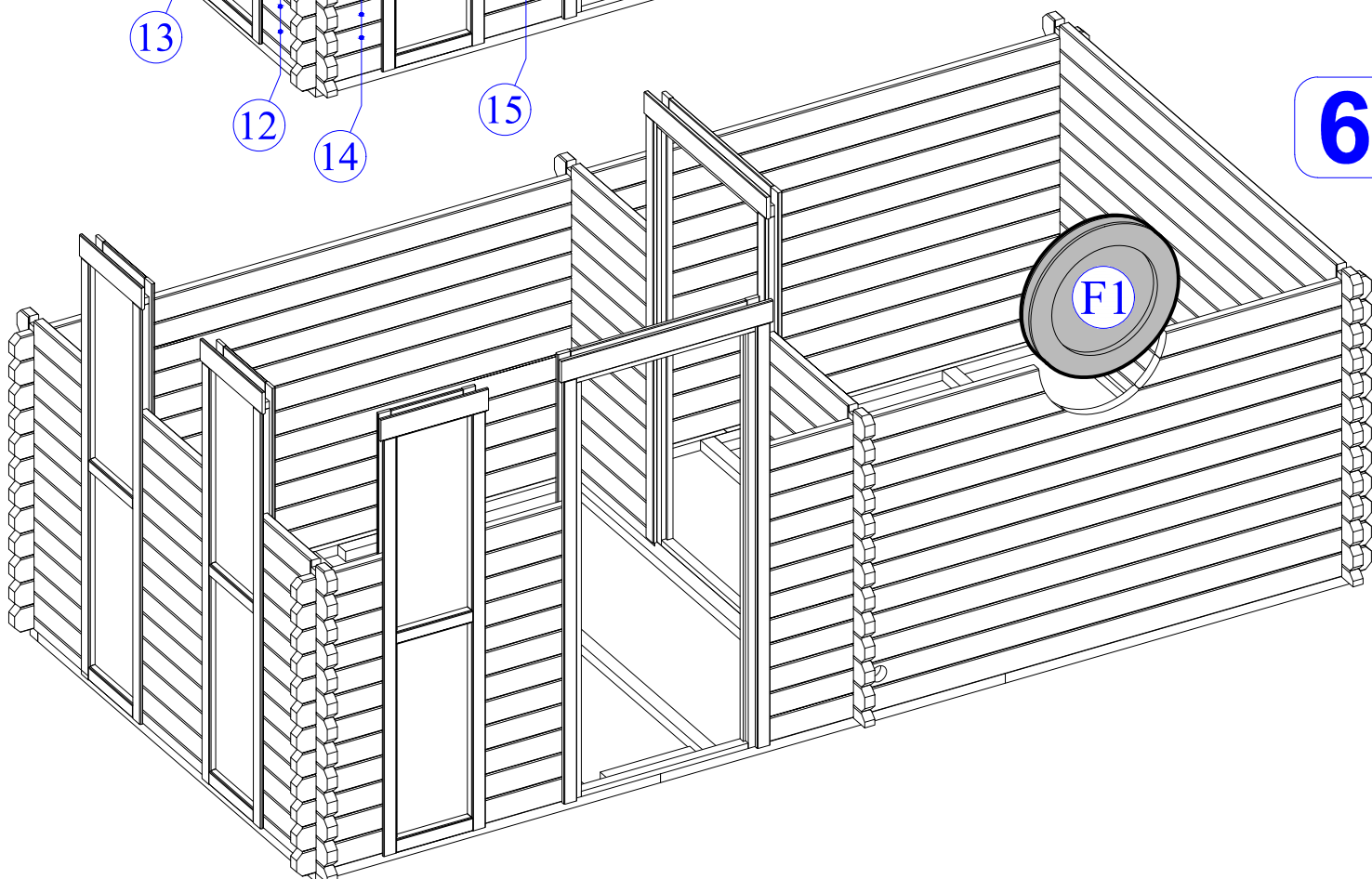

7

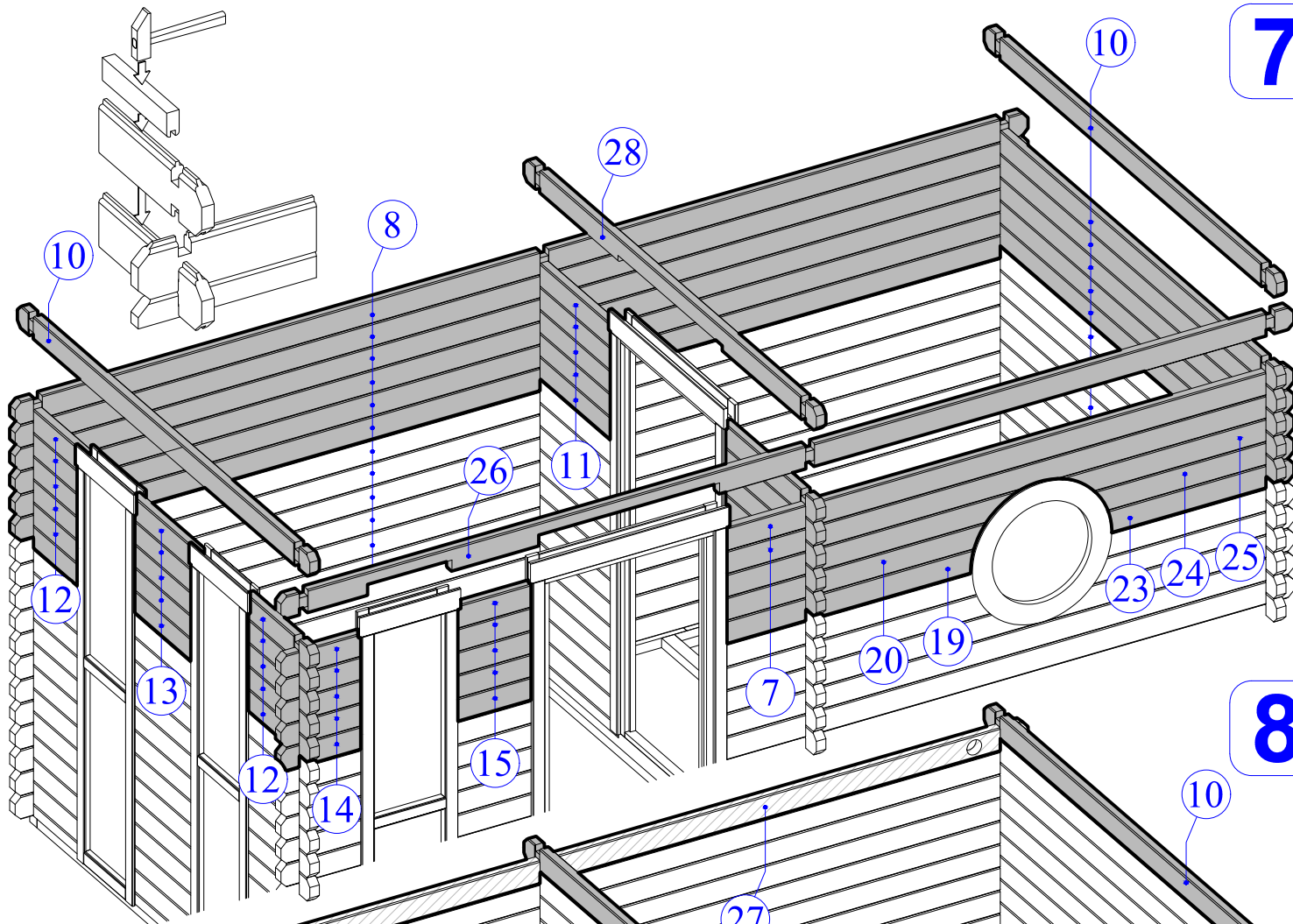

8

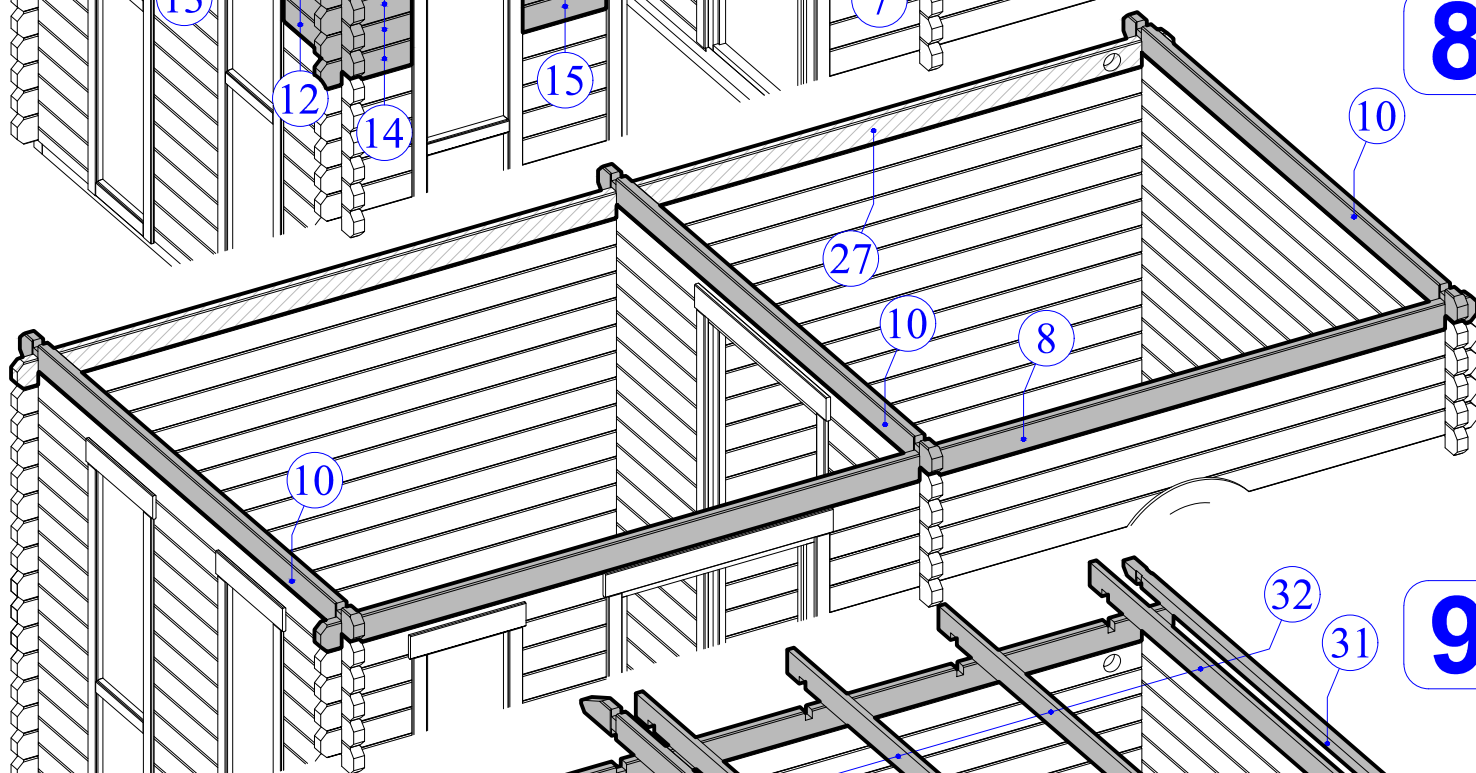

9

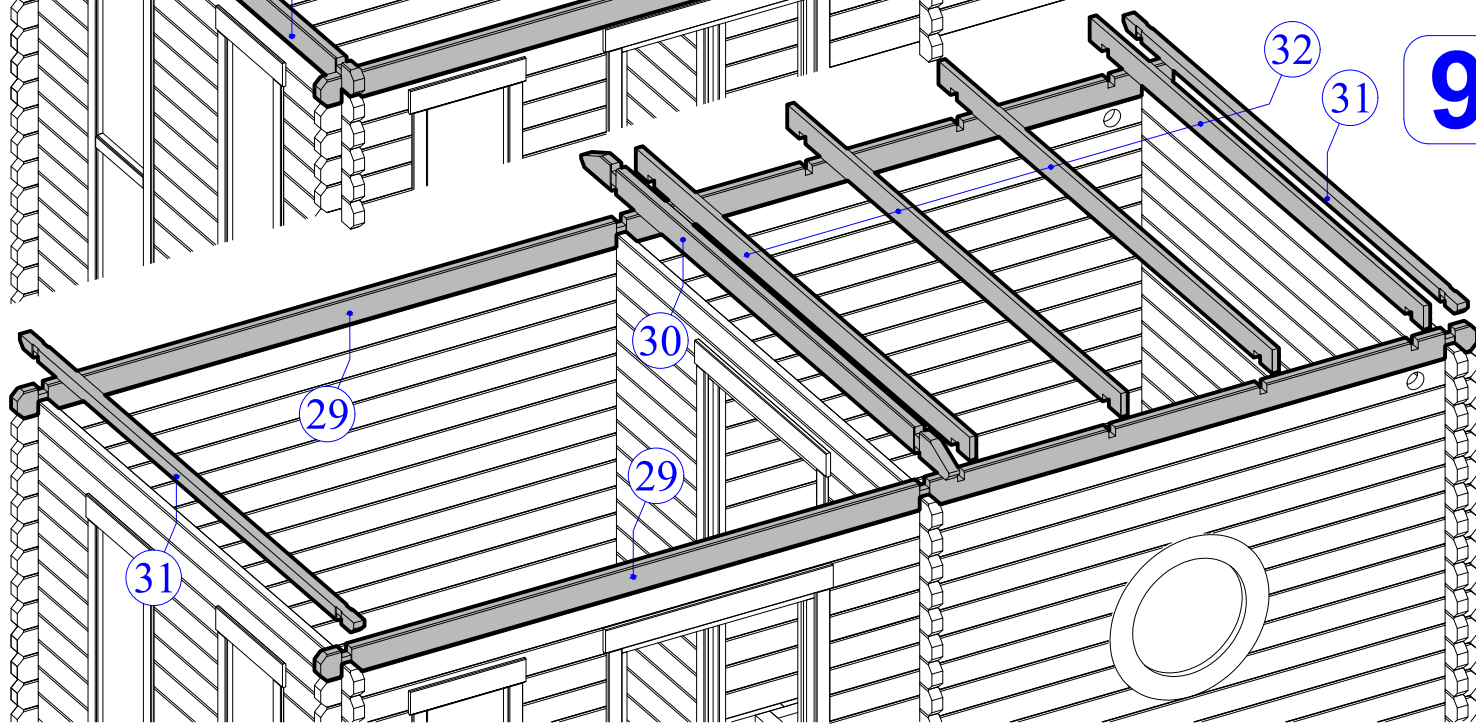

10

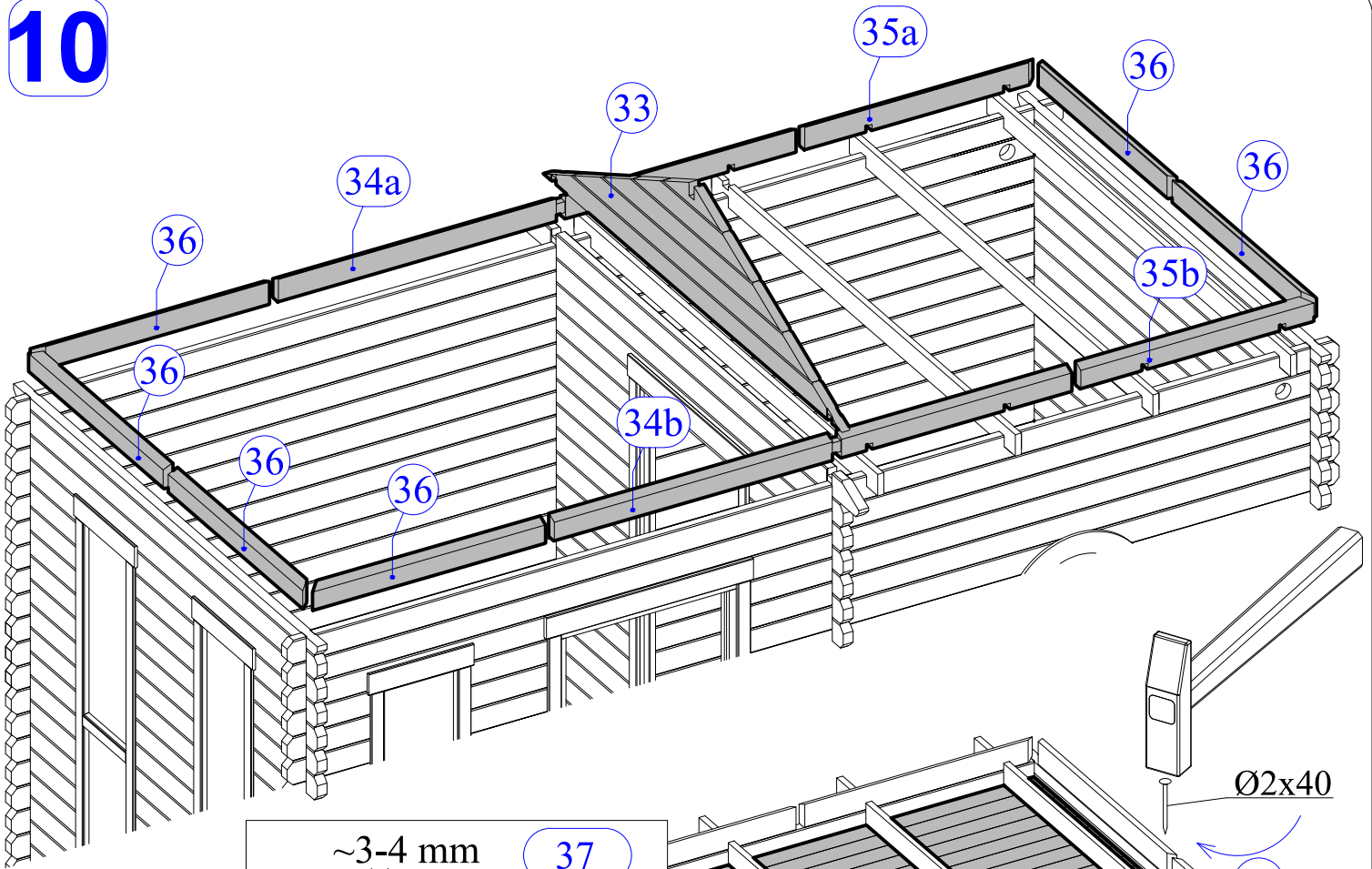

11

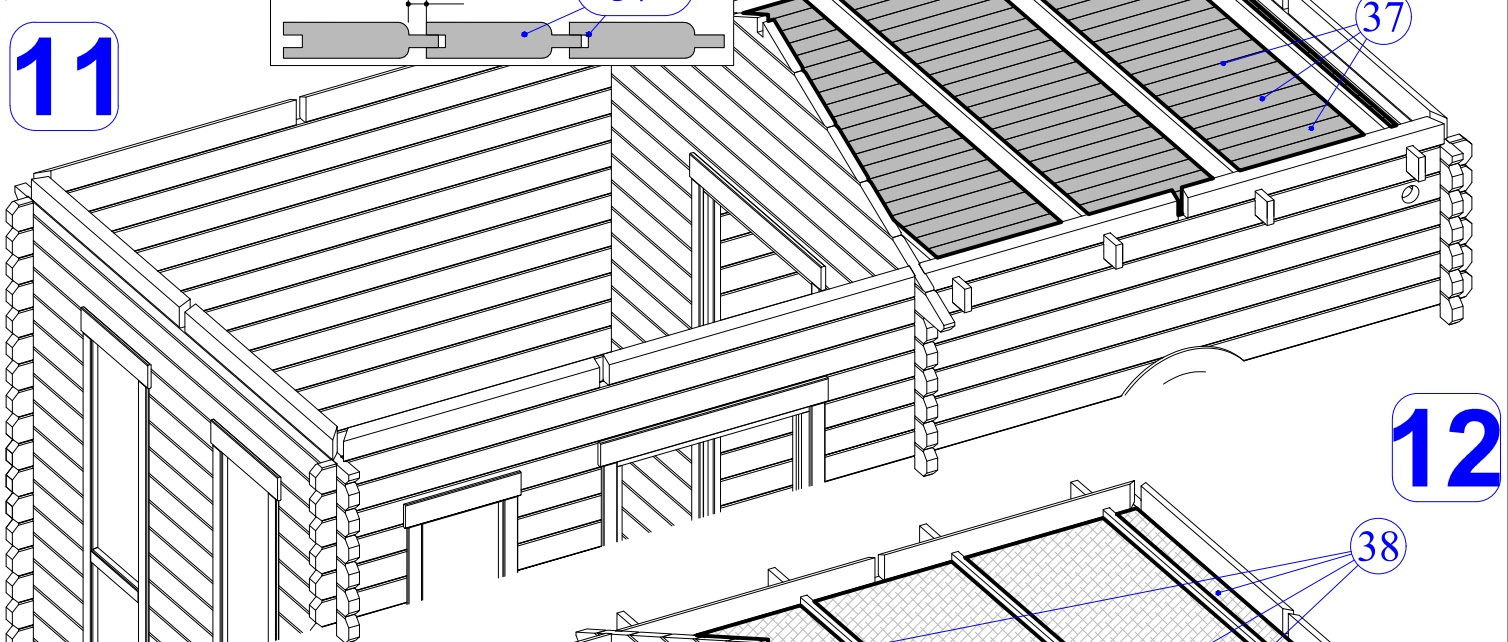

12

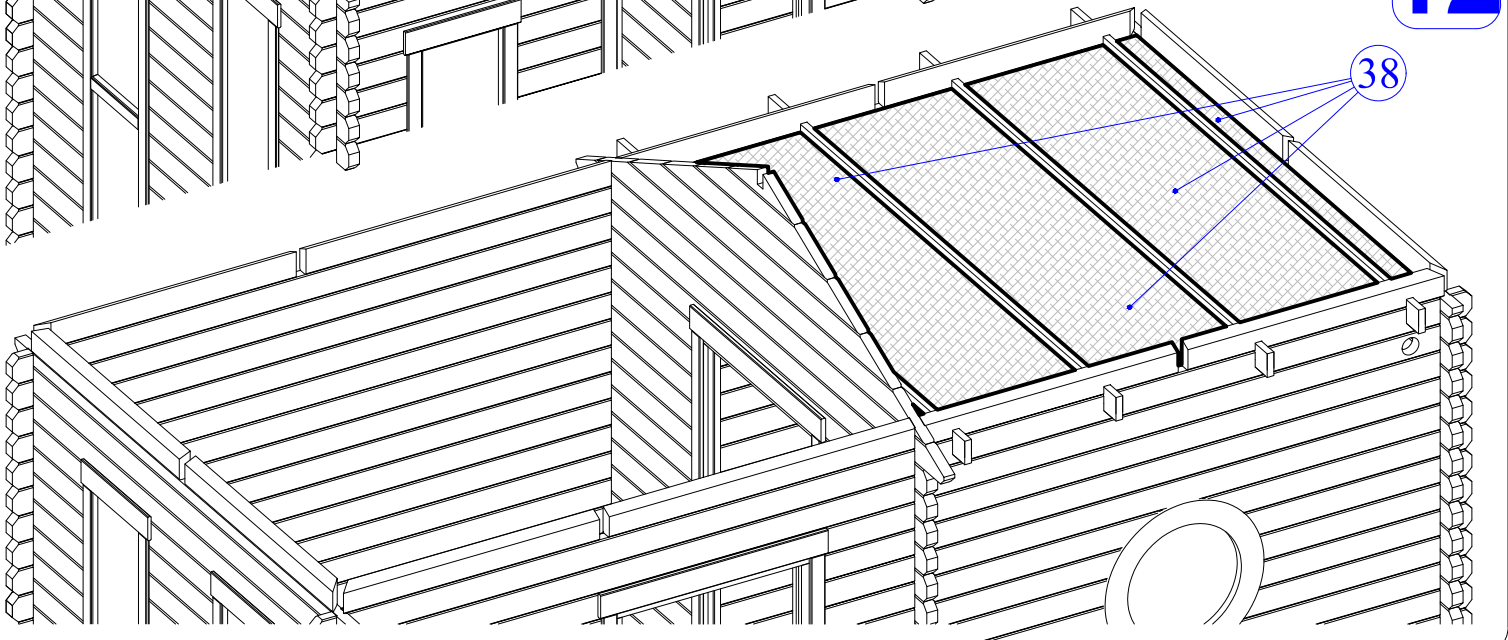





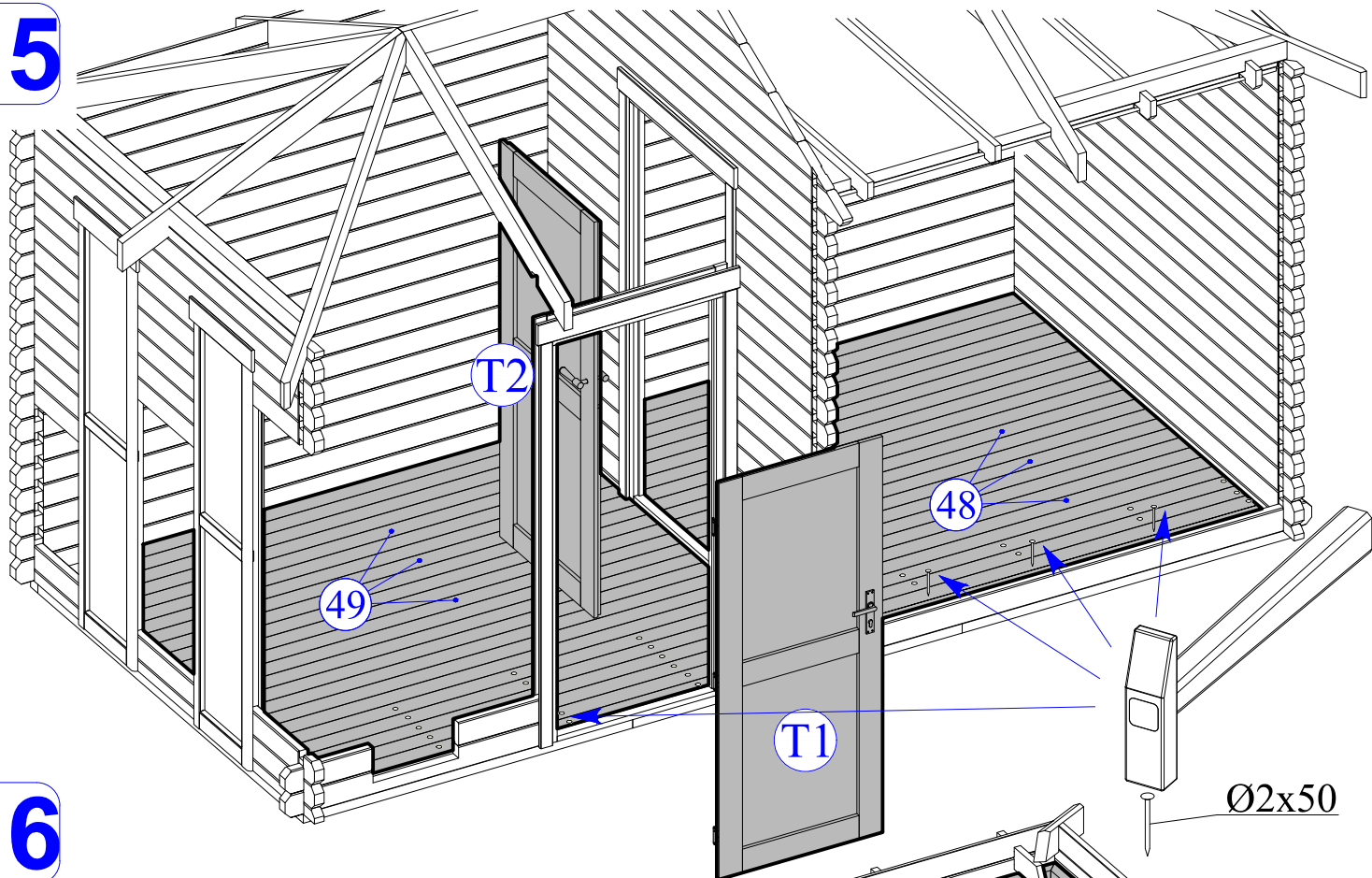



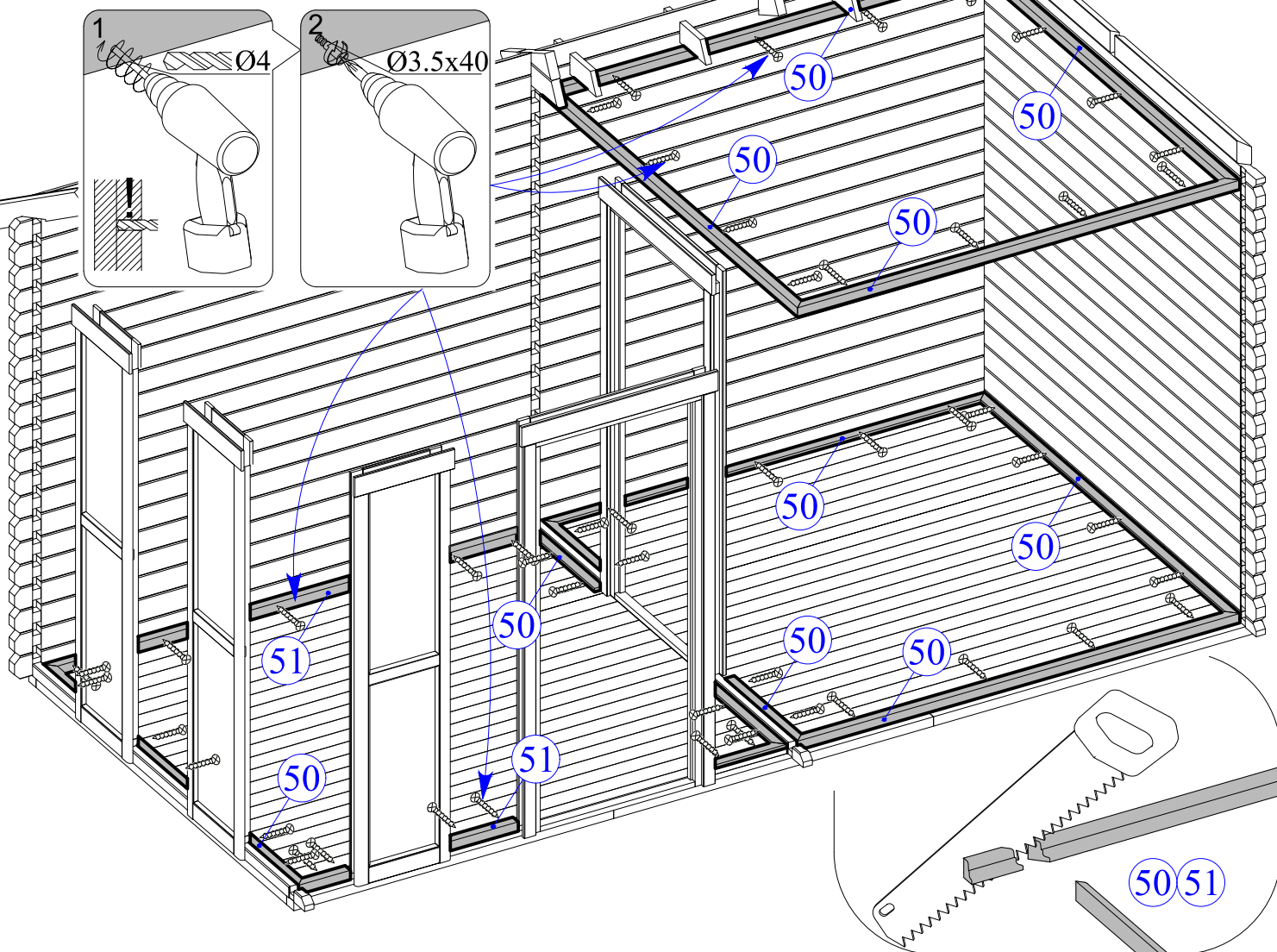

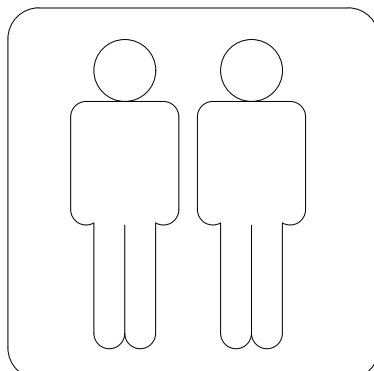
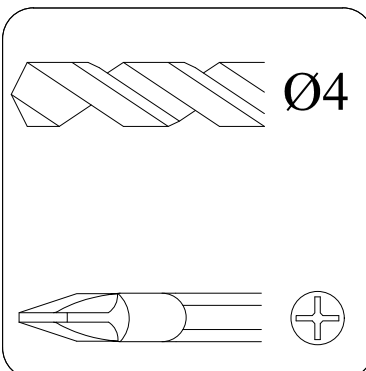
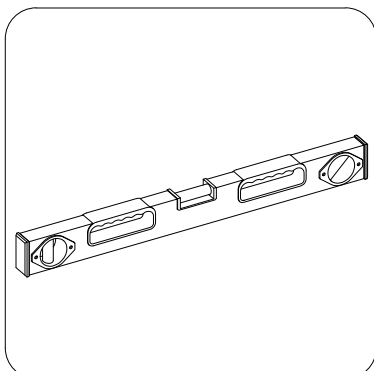
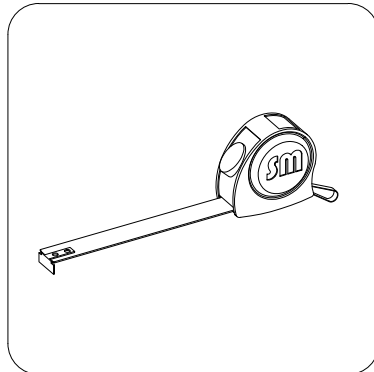
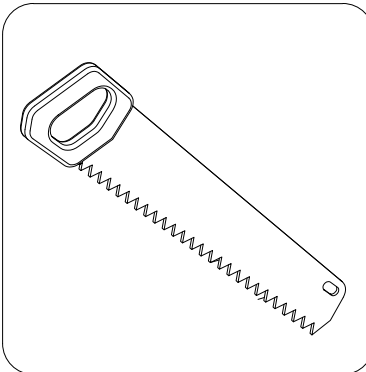
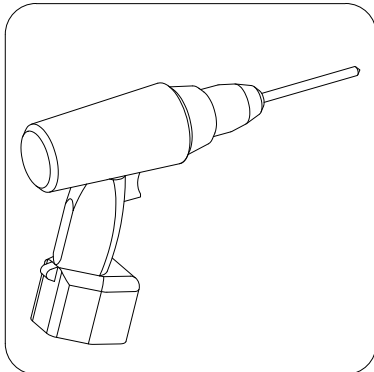
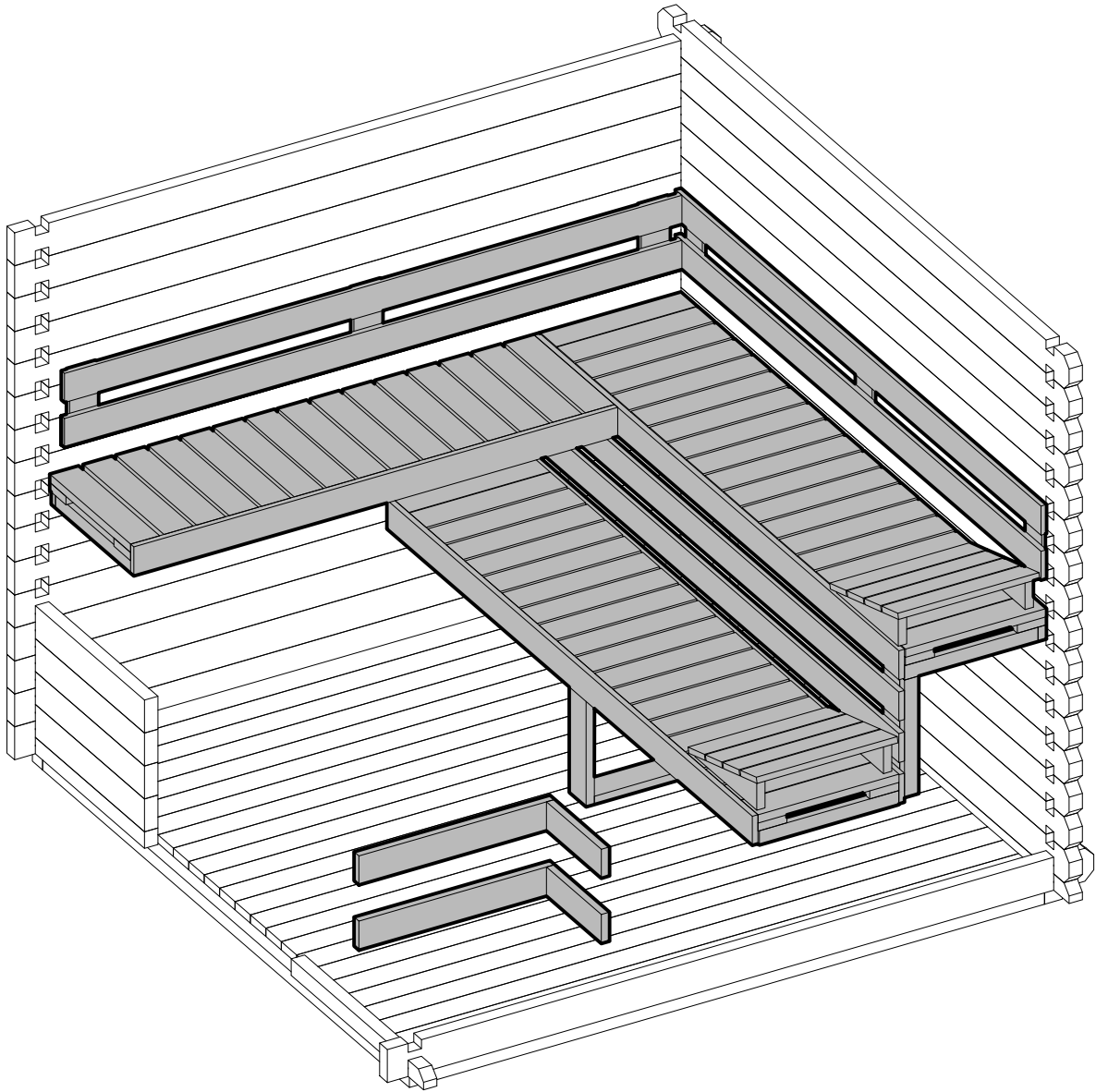

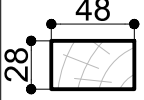
15

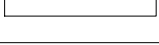
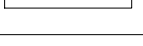

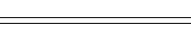
16

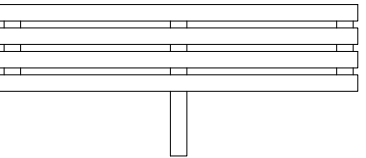
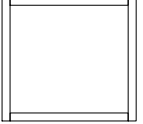
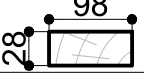

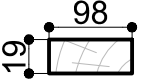

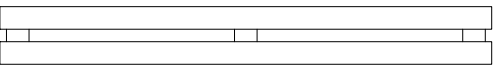
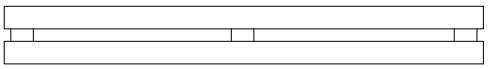
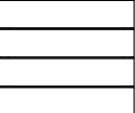
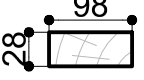
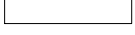
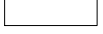
Dim.	Skizze/Sketch	Pos.	Länge/length (mm)	Stck. /Total	Name	Ref.
		①	2135 (1070x2)	1	Latten Lath	287107
		②	1500	1		287108
		③	575	2		287110
		④	440	1		287112
		⑤	397	2		287109
		⑥	600	2		287111
		⑦	600 x 2135	2	Bank Bench	287113
		⑧	475 x 1500	1	Bank Bench	287114
		⑨	516 x 2135	1	Bank Bench	287115
		⑩	430 x 590	1	Unterstützung Bench support	287116
		⑪	595	1	Stützbalken Support	287124
		⑫	2135	1	Abdeckbrett Cover board	287122
		⑬	1500	1	Abdeckbrett Cover board	287123
		⑭	250 x 2135	1	Rückseite brett Backrest	287118
		⑮	250 x 2097	1	Rückseite brett Backrest	287119
		⑯	300 x 475	2	Pad Pad	287117
		⑰	320	2	Rückseite brett Cover board	287120
		⑱	660	2	Rückseite brett Cover board	287121

Ø4.5 x 90 -17

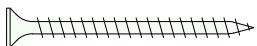

Ø3.5 x 45 -69



Ø3.5 x 25 -36



-6

1

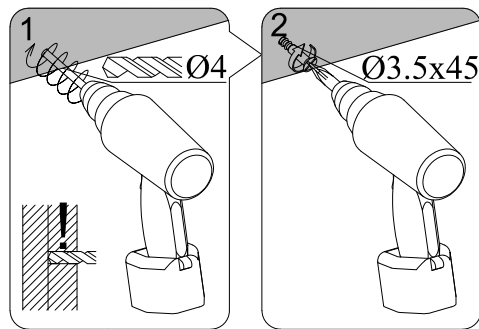
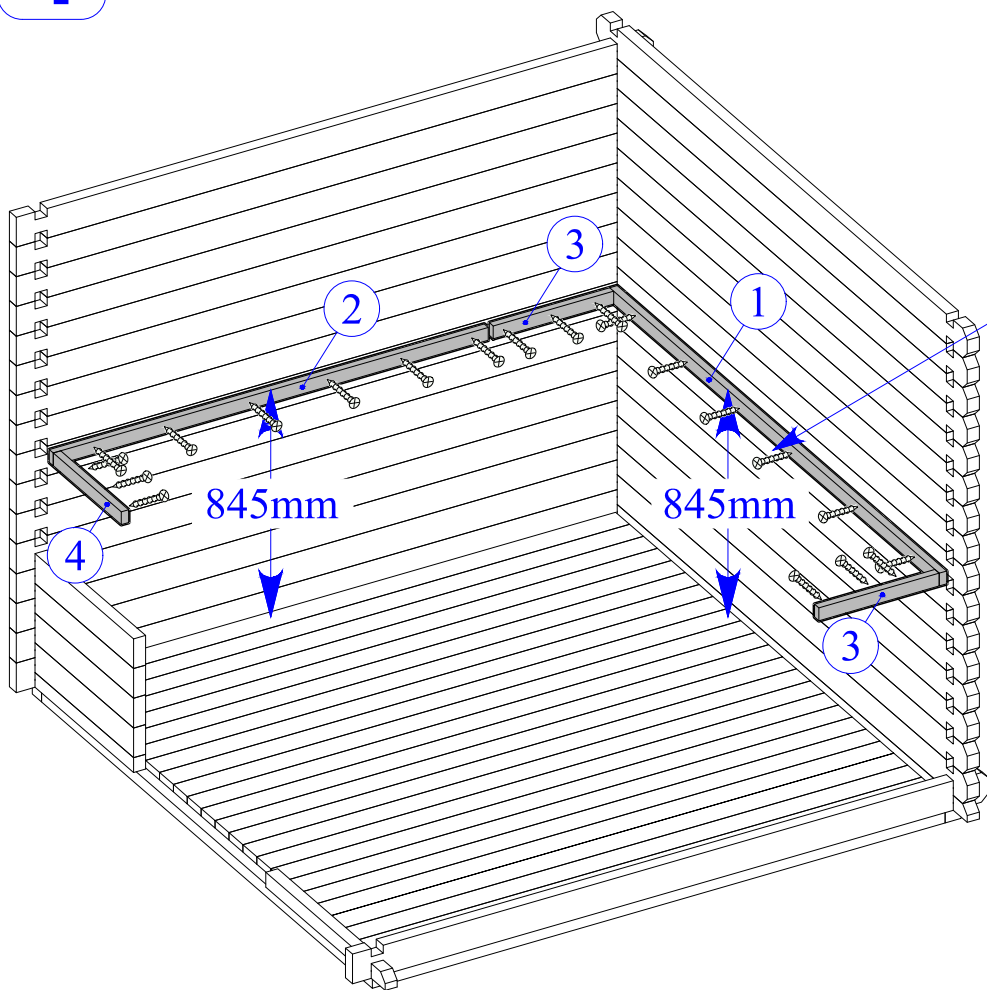

2

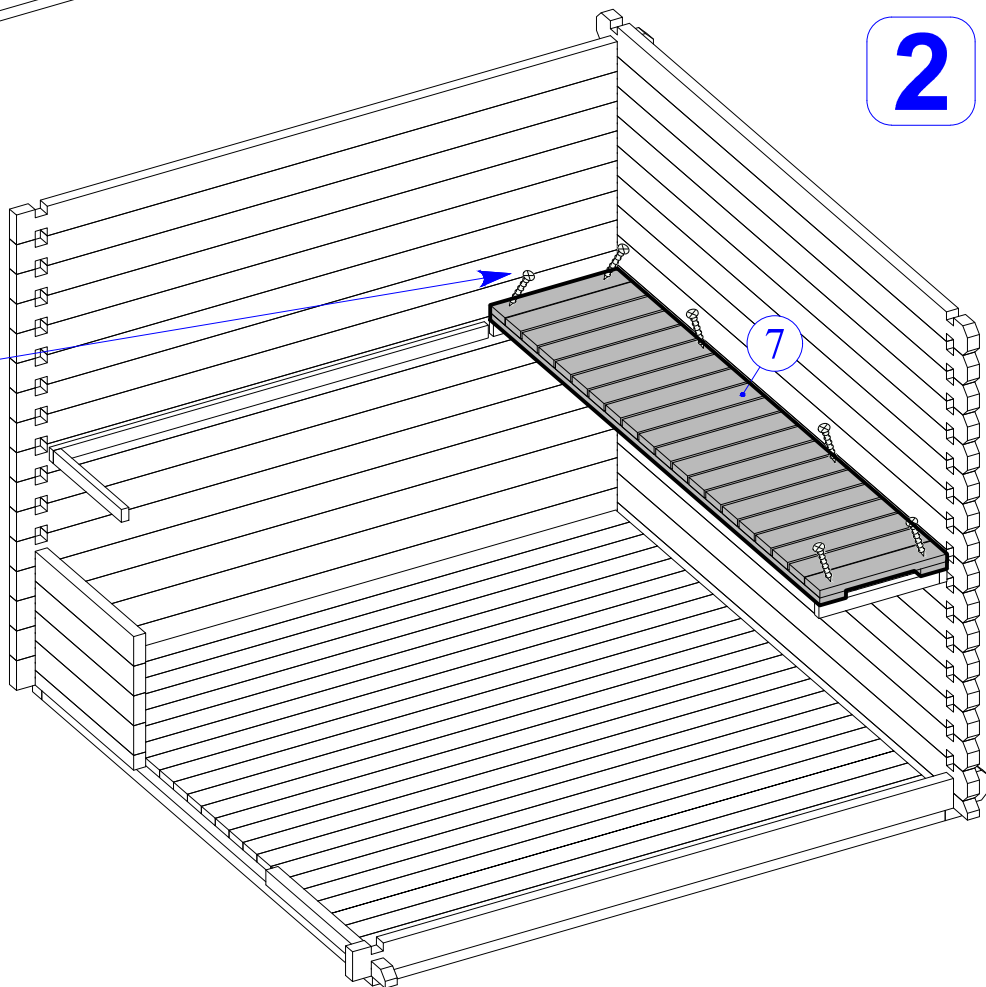
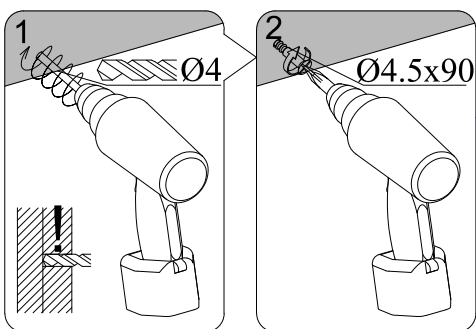

**3**

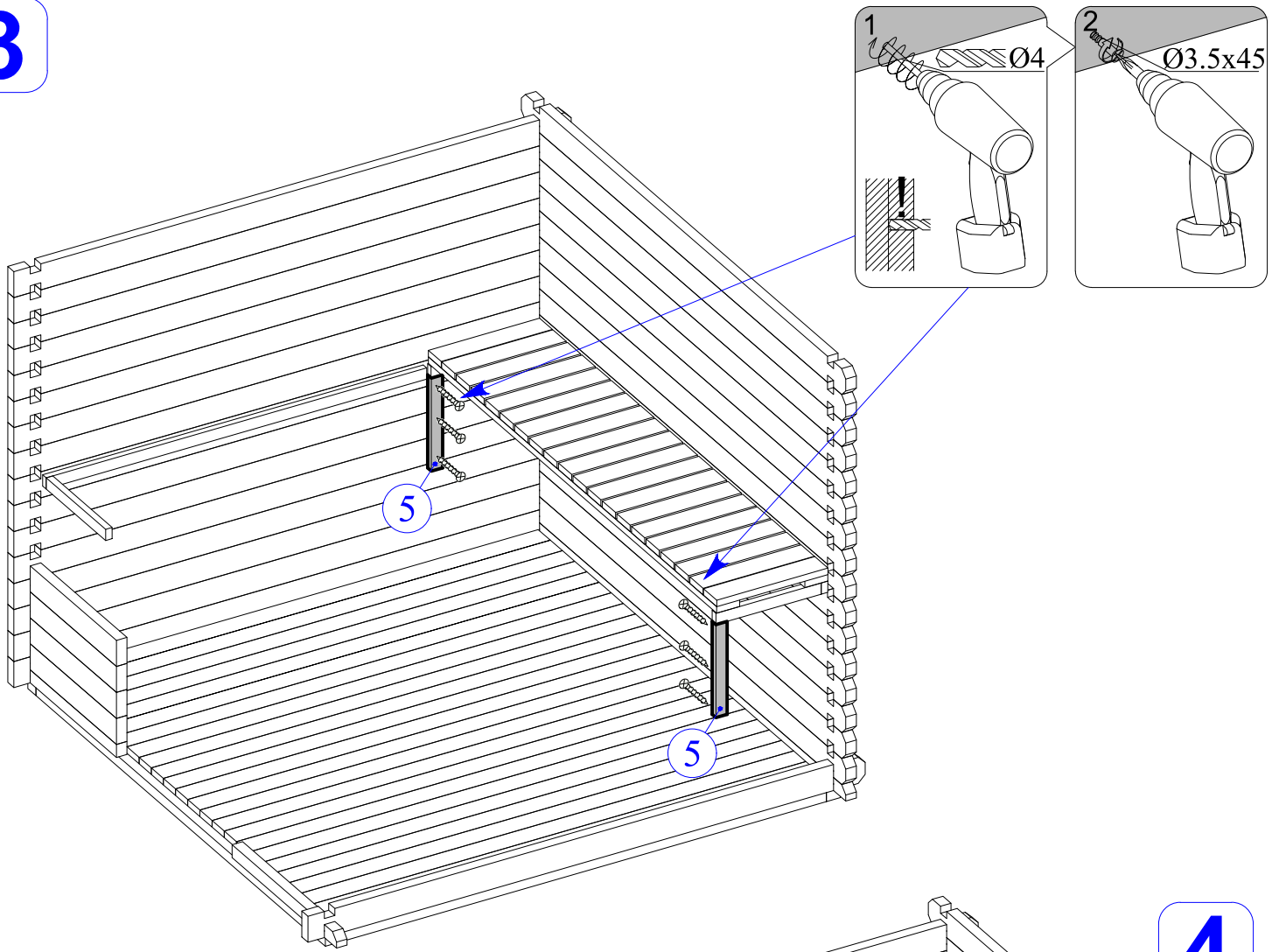

**4**

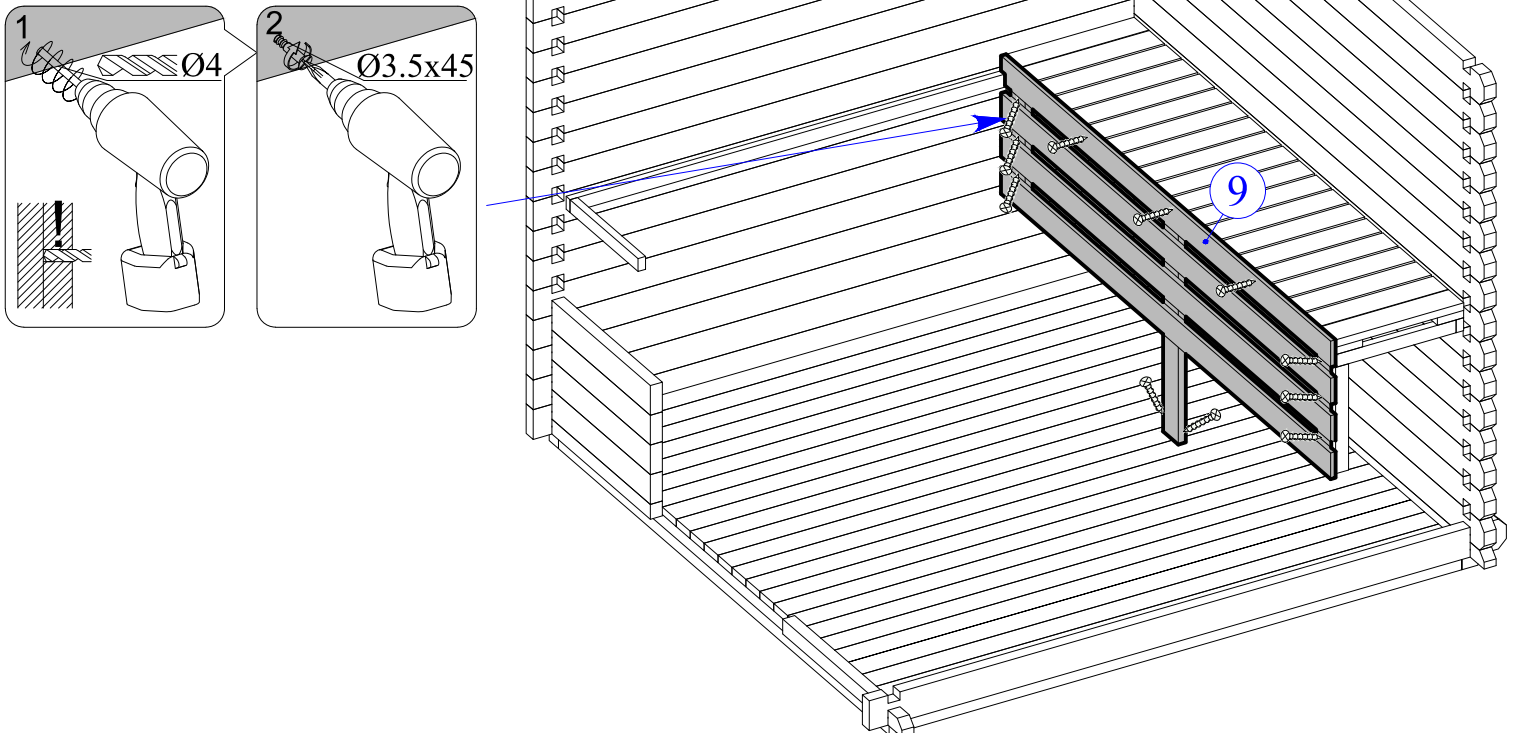

## 5

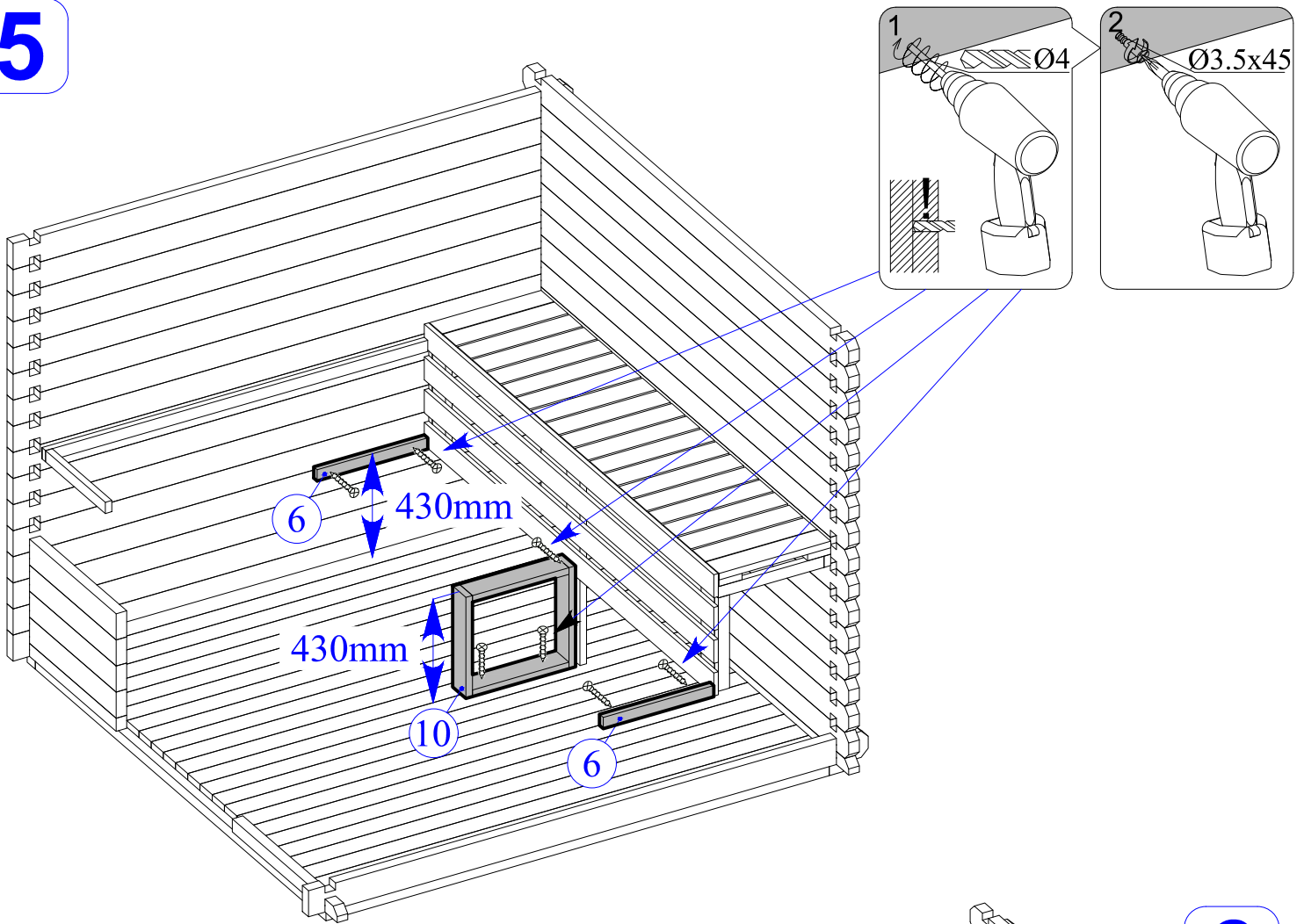

## 6

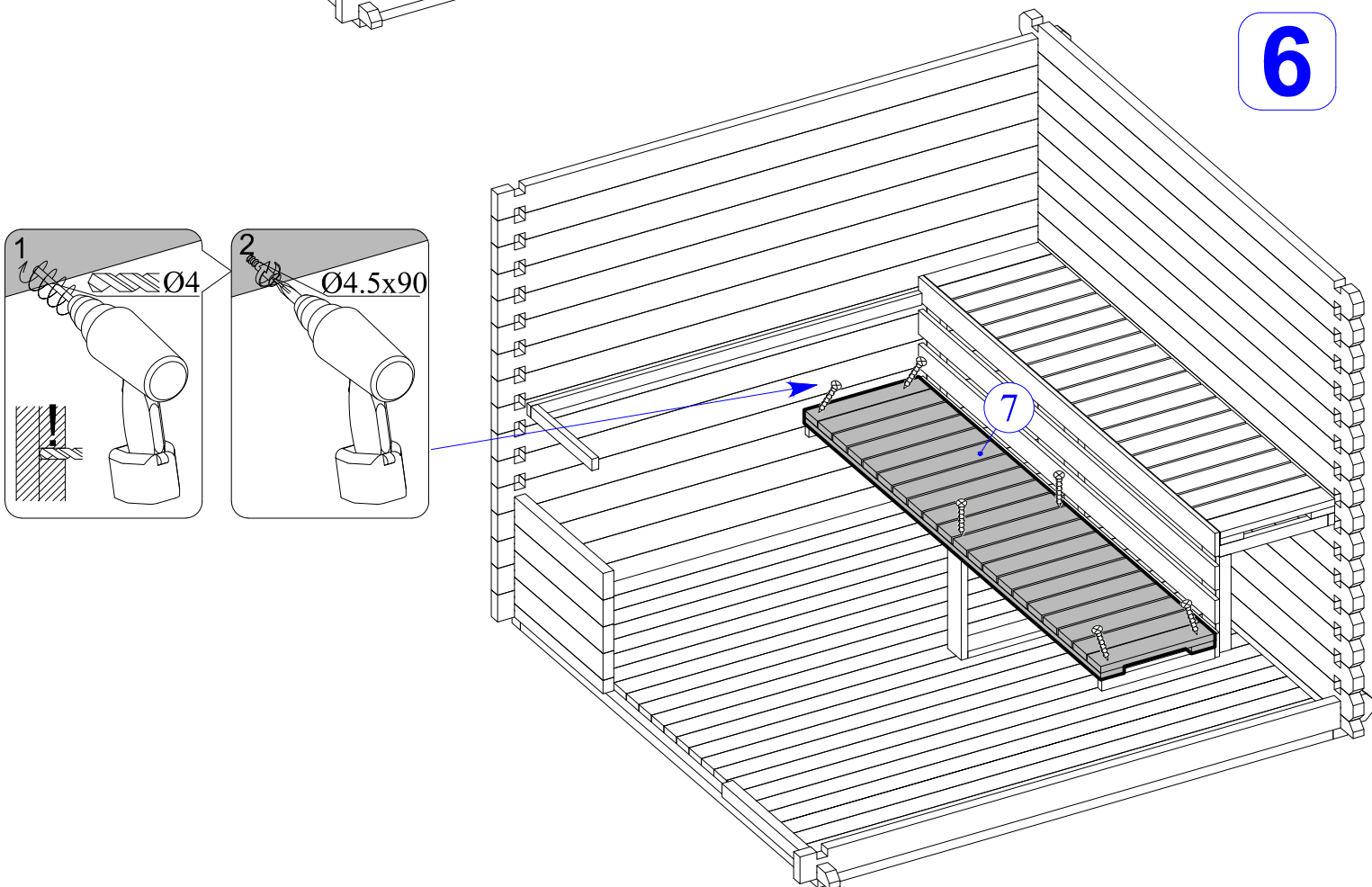

7

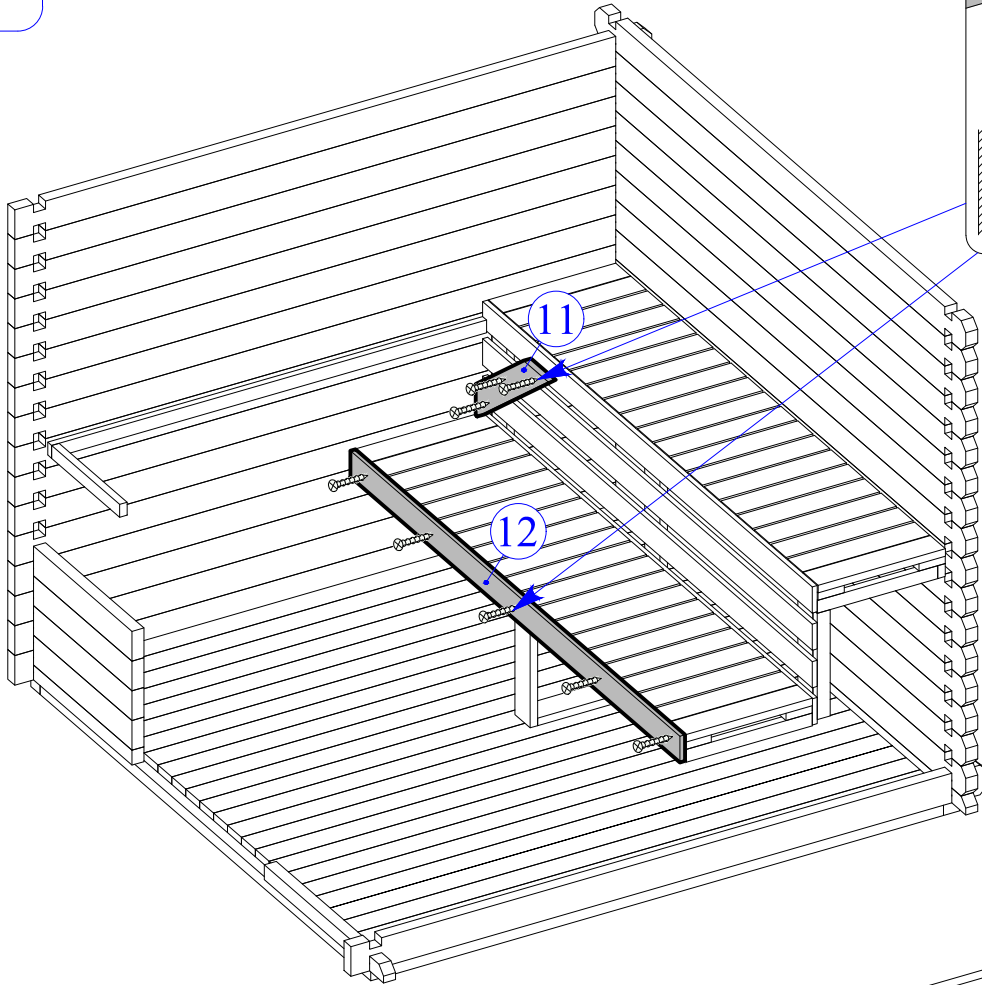
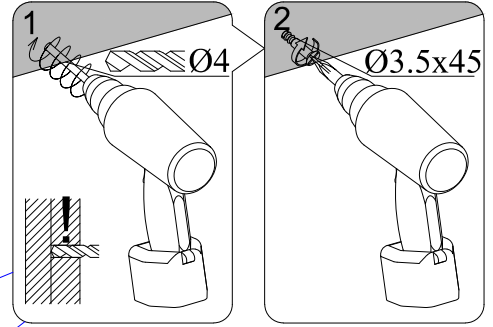

8

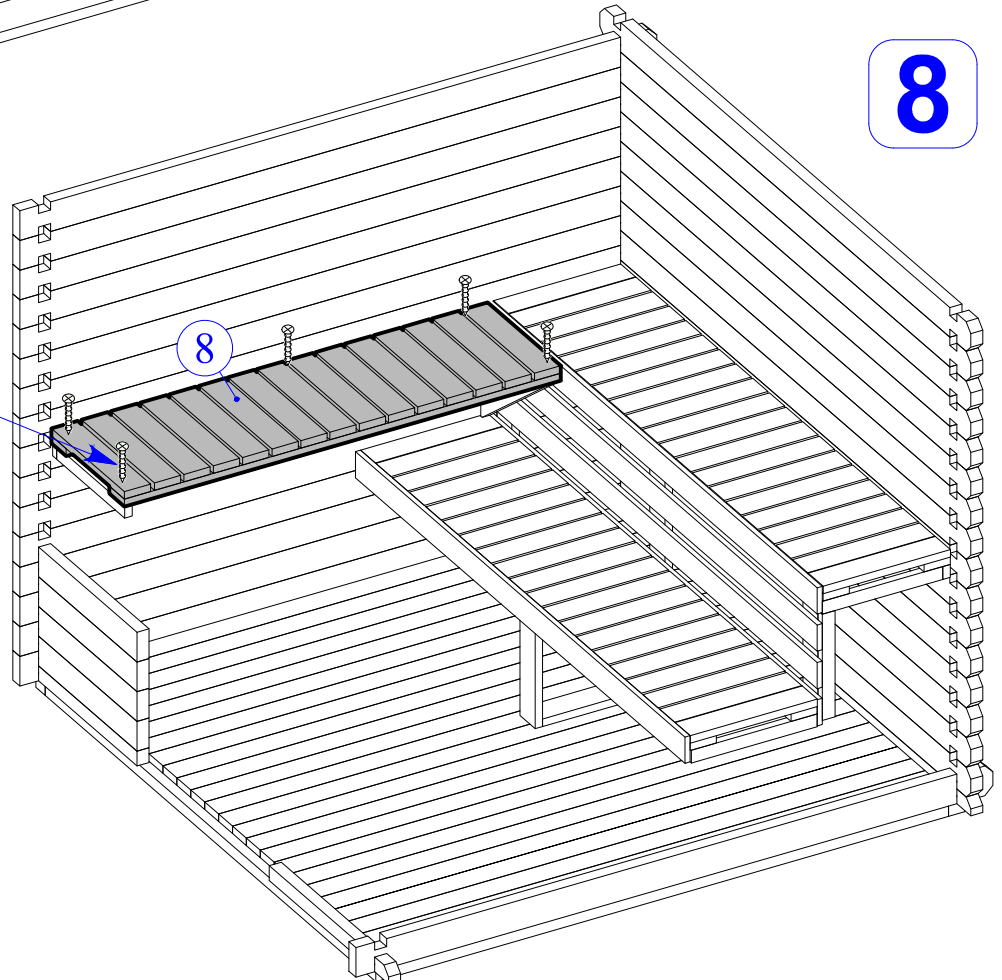
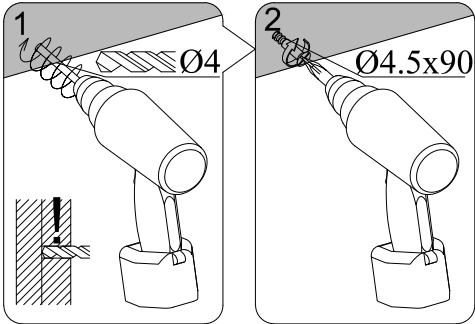

9

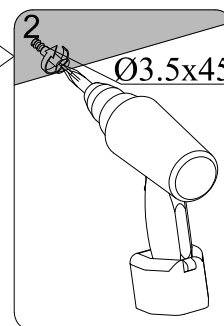
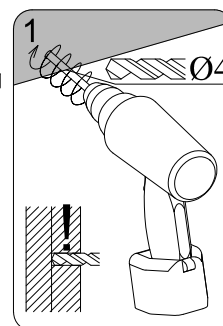
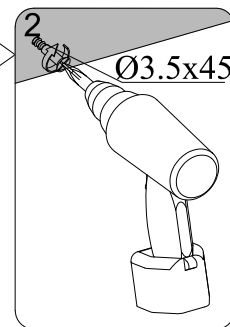
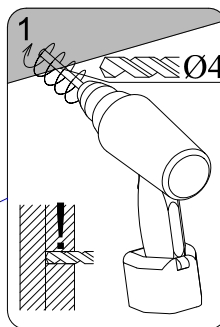
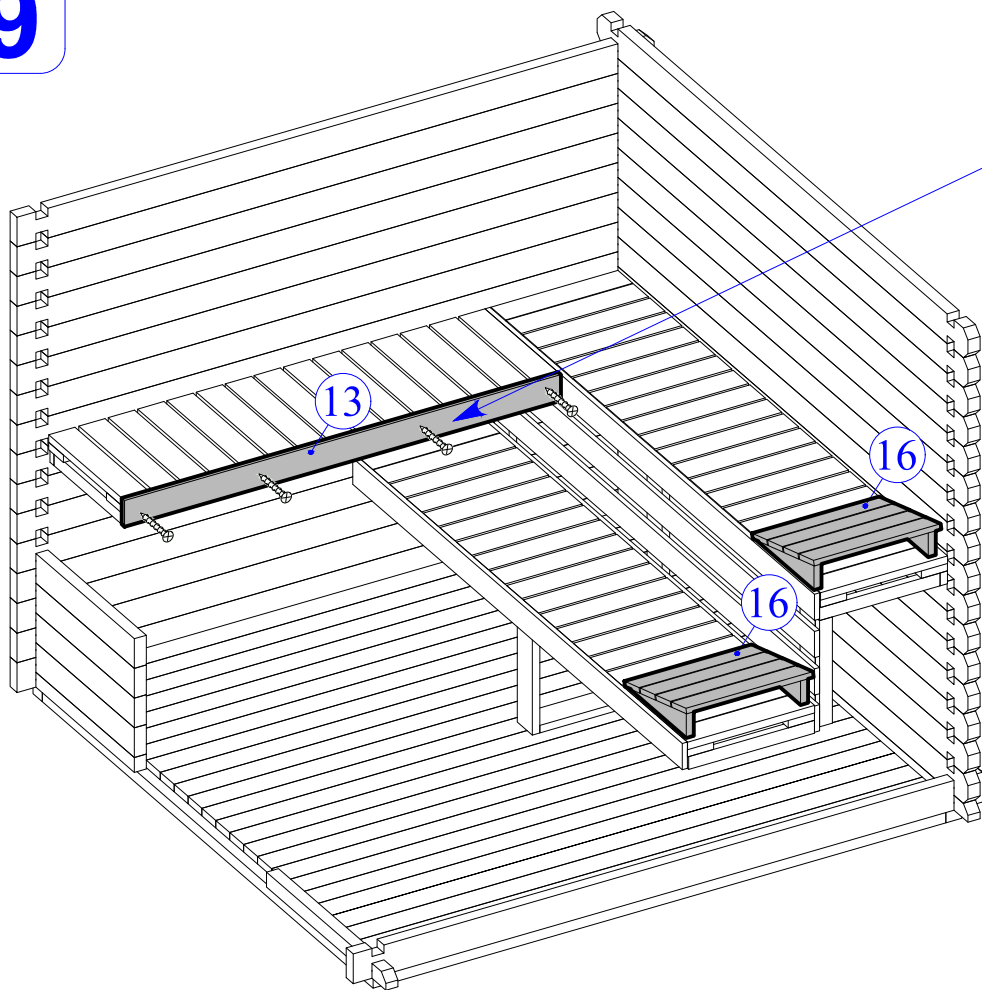

10

